

PERIMETER FLASHING

Table of Contents

	Page
1.0 SCOPE	3
1.1 Hazards	3
1.2 Changes	3
2.0 LOSS PREVENTION RECOMMENDATIONS	3
2.1 Introduction	3
2.2 Construction and Location	3
2.2.1 Flashing Ratings and Installation of FM Approved Perimeter Flashing Systems	3
2.2.2 Wood Nailers	5
2.2.3 Cant Strips	8
2.2.4 Base Securement of Adhered Single-Ply Membranes with Reinforced Membrane Attachment Strips	8
2.2.5 Mechanical Fastening for Single-Ply Membranes Adhered to Walls or Parapets above Roof Assemblies	9
2.2.6 Metal Counter-Flashing	9
2.2.7 Flashing Systems at MFL Fire Walls	11
2.2.8 Securing Flashing to Existing Metal Panel Walls	11
2.2.9 Sealing Spaces between Walls and Roofs	11
2.2.10 Gutter Systems Gravity Load	11
2.2.11 Roof Drainage	11
2.2.12 Flashing Systems and Roof-Mounted Photovoltaic Panels	11
2.3 Operation and Maintenance	11
3.0 SUPPORT FOR RECOMMENDATIONS	12
3.1 Flashing Details for Multi-Ply Roof Covers	12
3.1.1 Masonry Wall with Roof Edge Cant with Multi-Ply Roof Cover	12
3.1.2 Masonry Wall with High Parapet and Multi-Ply Roof Cover	15
3.1.3 Cantilevered Wood Nailers	16
3.1.4 Panel Wall With Parapet and Multi-Ply Roof Cover	17
3.1.5 Metal Gravel Guards and Fascias	17
3.1.6 Gutters	19
3.2 Single-Ply Membrane (SPM) Flashing Details	19
3.2.1 General	19
3.2.2 Membrane Terminations	20
3.2.3 Reglets	21
3.2.4 Termination Bars	25
3.2.5 Masonry Anchors and Fasteners	25
3.2.6 Parapets	25
3.2.7 Base Securement of Adhered Single-Ply Membranes with Reinforced Membrane Attachment Strips (RMAS)	25
3.3 Roof Penetrations	27
3.4 Resistance of FM Approved Flashing	27
3.5 Example Problems	28
3.5.1 Example Problem 1: Fully Adhered Roof Cover	28
3.5.2 Example Problem 2: Mechanically Fastened Roof Cover	32
3.6 Loss History	32
3.7 Illustrative Losses	32
3.7.1 Hurricane Winds Strike Building Corner	32
3.7.2 Hook Strip Not Provided	33



3.7.3 Hooking of Metal Fascia Inadequate	33
4.0 REFERENCES	34
4.1 FM Global	34
4.2 Others	34
APPENDIX A GLOSSARY OF TERMS	34
APPENDIX B DOCUMENT REVISION HISTORY	36

List of Figures

Fig. 2.2.4.2.1-1. Reinforced membrane attachment strip with stress plate approximately 1 in. (25 mm) from edge	9
Fig. 2.3.2-1. Existing perimeter flashing secured at its lower edge	12
Fig. 3.1.1-1. Multi-ply roof cover with perimeter edge flashing detail	13
Fig. 3.1.1-2. Multi-ply roof cover with roof edge cant and wood fascia	13
Fig. 3.1.1-3. Multi-ply roof cover with roof edge fascia cap (cant) flashing	14
Fig. 3.1.1-4. Detail A from Figure 3.1.1-3	14
Fig. 3.1.2-1. Multi-ply roof cover with masonry wall with high parapet	15
Fig. 3.1.3-1. Multi-ply roof with panel wall with roof edge cant, nailer bolted to roof joistsg	17
Fig. 3.1.3-2. Multi-ply roof cover with panel wall with roof edge cant, nailer screwed to roof deck	18
Fig. 3.1.3-3. Multi-ply roof with panel wall with roof edge cant, nailer screwed to deck	18
Fig. 3.1.4-1. Panel wall with parapet and multi-ply roof cover	19
Fig. 3.1.5-1. Metal gravel guard fascia flashing	20
Fig. 3.1.6-1 Metal gutter with fascia flashing	20
Fig. 3.2.2-1. Single-ply membrane with metal gravel guard fascia flashing	21
Fig. 3.2.2-2. Single-ply membrane roof with edge cap (cant) fascia flashing	22
Fig. 3.2.2-3. PVC membrane edge detail with gravel stop	22
Fig. 3.2.2-4. Single-ply membrane roof with drip (drainage) fascia flashing	23
Fig. 3.2.3-1. Single-ply membrane wall or parapet terminations with reglets	23
Fig. 3.2.3-2. Single-ply membrane attachment to precast walls (where reglet was not formed)	24
Fig. 3.2.3-3. Single-ply membrane termination under parapet coping	24
Fig. 3.2.7-1. Reinforced membrane attachment strip secured to roof deck	26
Fig. 3.2.7-2. Reinforced membrane attachment strip secured to a wall	26
Fig. 3.2.7-3. Wind uplift test on adhered single-ply membrane with reinforced membrane attachment strip (RMAS)	27
Fig. 3.5.1.1.1-1. RoofNav's ratings calculator output	29
Fig. 3.5.1.1.2-1. RoofNav's product search	30
Fig. 3.5.1.1.3-1. RoofNav's product detail report	31
Fig. 3.5.1.1.3-2. RoofNav's product details	31
Fig. 3.6-1. Examples of perimeter flashing installations THAT ARE NOT RECOMMENDED	33

List of Tables

Table 2.2.2.3.2-1. Maximum Spacing for ½ in. (13 mm) Anchor Bolts Securing Wood Nailers to Structural Concrete or Reinforced Concrete Masonry Unit Walls	6
Table 2.2.2.3.2-2. Maximum Spacing for 3/8 in. (10 mm) Anchor Bolts Securing Wood Nailers to Structural Concrete or Reinforced Concrete Masonry Unit Walls	6
Table 2.2.2.3.4-1. Maximum Spacing Within Each Row (2 rows required) for Fasteners Securing Wood Nailers to Structural Concrete Decks or Minimum 22 ga. (0.0295 in. [0.75 mm]) Steel Decks	7
Table 2.2.2.3.6-1. Maximum Spacing Within Each Row (2 Rows Required) for Fasteners Securing Wood Members to Wood Nailers	8
Table 2.2.6-1. Maximum Counter-Flashing Height ("L" Dimension in Figures) and Metal Thicknesses (in.) ..	10
Table 2.2.6-2. Maximum Counter-Flashing Height ("L" in Figures) and Metal Thicknesses (mm)	10
Table 2.2.8-1. Maximum Fastener Spacing for Flashing Secured Directly to Existing Metal Panel Walls ..	11
Table 2.3.1-1. Maximum Fastener Spacing to Secure Loose Flashing to wood and masonry	12
Table 3.4-1. Minimum Resistances for FM Approved Flashing Systems ¹	28

1.0 SCOPE

This data sheet provides guidance for determining wind ratings and installing FM Approved perimeter roof flashing and external gutter systems. Flashing systems include:

- A. Fascia systems used with membrane roofs, which include built-up coverings (BUR), modified bitumen (mod-bit) coverings, single-ply membrane coverings (SPM), and liquid applied roof coverings.
- B. Metal coping systems used over the top of parapets for any roof type.

Wind ratings are calculated using RoofNav's Ratings Calculator then used in RoofNav's Product Search to select FM Approved systems. Guidance for wood nailers and other perimeter roof components, including base flashings if roof assemblies intersect higher walls (including parapets), is also provided, along with inspection and maintenance guidelines.

For new construction, use this data sheet in conjunction with the roofing specifications. The recommendations are intended as a guide to secure the roof cover and to prevent perimeter flashing from blowing off.

Differential movement between the building roof and wall can introduce stresses into the flashing components. Such movement should be carefully considered by the architect or engineer responsible for the building design.

For information on various roof coverings their maintenance, securement, and wind design, see RoofNav and Data Sheet 1-32, *Inspection and Maintenance of Roof Assemblies*; Data Sheet 1-28, *Wind Design*; and Data Sheet 1-29, *Roof Deck Securement and Above-Deck Roof Components*.

1.1 Hazards

Properly installed perimeter edge flashing is critical to securing the roof cover to the building and preventing loss of the roof cover and resultant water intrusion and damage from windstorms. See FM Global publications *Roof Fix-It Guide: Perimeter Flashing* (P9403a) and *Protecting Roofing Systems Against Windstorm Damage* (P0283) for additional information.

1.2 Changes

October 2021. This document has been completely revised. The following significant changes were made:

- A. Revised design guidance for calculating flashing ratings to reflect changes in pressure coefficients in Data Sheet 1-28 and ASCE 7-16.
- B. Deleted Table 1 because RoofNav's Ratings Calculator is now used to calculate flashing ratings.
- C. Information in 2.2.7, Flashing Systems at MFL Fire Walls, has been deleted and recommends using Data Sheet 1-42, *Maximum Foreseeable Loss Limiting Factors*.

2.0 LOSS PREVENTION RECOMMENDATIONS

2.1 Introduction

The following recommendations are intended to provide perimeter flashing systems, gutters, wood nailers, and other perimeter roof components with the proper wind resistance to secure the roof covering and protect the building and interior contents for the weather. RoofNav's Ratings Calculator is used to calculate flashing ratings and RoofNav's Product Search is used to select FM Approved perimeter flashing and gutter systems. FM Approved perimeter flashing systems are monitored under the FM Approvals Surveillance Audit program.

Use FM Approved equipment, materials, and services whenever they are applicable and available. For a list of roofing products that are FM Approved, see www.roofnav.com.

2.2 Construction and Location

2.2.1 Flashing Ratings and Installation of FM Approved Perimeter Flashing Systems

2.2.1.1 Use FM Approved fascia or gutter systems at roof edges (where the roof transitions to a lower vertical or near-vertical wall) with membrane covered roofs.

Use FM Approved coping on top of parapets.

Determine flashing and gutter ratings and install them in accordance with recommendations 2.2.1.2 through 2.2.1.9.

In the tables and figures, zone 2 includes zones 2e and 2n, and zone 3 includes zones 3e and 3r.

2.2.1.2 Use RoofNav's Ratings Calculator and DS 1-28 to calculate the following:

A. Zone 2 perimeter flashing and gutter rating(s) for Zones 2, 2e or 2n and Zone 3 corner flashing rating(s) for Zones 3, 3e or 3r when present. Coping and fascia's may have different ratings.

Use the recommended Zone 2 perimeter rated gutters in Zone 3 because gutters do not have a Zone 3 corner rating.

B. Zone 1 roof rating.

C. Dimensions for Zones 3, 3e, or 3r when present.

Flashing ratings are not reduced when minimum 3 ft (91.0 m) continuous parapets are present.

2.2.1.3 Use RoofNav to select FM Approved system(s) with the minimum recommended Zone 2 perimeter rating for Zones 2, 2e, or 2n, and Zone 3 corner rating for Zones 3, 3e, or 3r, when present. The vertical fascia height should be adequate for the drip edge bend to be a minimum 1 in. (25 mm) below the bottom of the bottom nailer. See Figure 3.1.1 detail A.

When adequately rated FM Approved gutters are not available, secure them behind properly rated FM Approved flashing. Space gutter brackets according to the FM Approval but not more than 30 in. (800 mm). See Fig. 3.1.6-1.

2.2.1.4 When selecting edge flashing systems (not for roof systems terminating at higher vertical walls or parapets), determine if the roof cover is independently terminated or dependently terminated. (See Appendix A for definitions and examples of independently terminated and dependently terminated roof systems.)

Ballasted systems and mechanically fastened single-ply roof covers where the distance from the outside edge of the nailer to the first row of fasteners is more than 12 in. (300 mm) are dependently terminated.

2.2.1.5 For dependently terminated roof covers, secure the roof cover to the roof deck with a row of FM Approved batten bars, stress plates or reinforced membrane attachment strips (RMAS) within 12 in. (300 mm) of the outside edge of the wood nailer. Use fasteners FM Approved for the securement of the roof cover to the roof deck spaced 6 in. (150 mm) maximum in Zones 2 and 3. (This additional edge securement, sometimes referred to as a "peel stop," changes a dependently terminated roof cover to an independently terminated one.)

2.2.1.6 Install the FM Approved fascia, coping or gutter assembly using fasteners of the type (screw or nail) and size and to the spacing's for Zone 2 and Zone 3 in the FM Approval listing in RoofNav. Increase fastener lengths by the width of any material(s) between these and the nailer. Follow the manufacturer's instructions for the fastener's material and coating (e.g., stainless steel, hot dip galvanized). Exposed screws should have a bonded sealing washer to prevent water intrusion.

When manufacturer's guidance is not available, fasteners should be corrosion resistant and compatible with the flashing material and wood nailer. When the wood nailer is treated wood, use stainless steel, hot-dipped galvanized steel complying with ASTM A153 (or equivalent), or fasteners with proprietary coatings recommended by the manufacturer for use in the specific type of treated wood. Uncoated aluminum and electroplated galvanized steel fasteners should not be used. Refer to the NRCA Roofing Manual: *Architectural Metal Flashing, Condensation and Air Leakage Control, and Reroofing*, for additional details.

2.2.1.7 Separate uncoated metal, including aluminum, or painted metal flashings and accessory products, except those of 300-series stainless steel, from pressure-treated wood (PTW) by a spacer or barrier such as a single-ply membrane or self-adhering modified bitumen membrane.

2.2.1.8 Install other components and seal to the roof cover to provide watertightness in accordance with the manufacturer's instructions. National Roofing Contractors Association (NRCA) guidelines provide additional direction along with Section 3.0 and Figures 3.1.1-1 through 3.2.7-2, which show common installation details. (Section 3.0 is for information only and does not include recommendations.)

2.2.1.9 Ensure good workmanship, attention to detail, and proper supervision at all times in the construction of the perimeter flashing assembly.

2.2.2 Wood Nailers

2.2.2.1 When to Provide Wood Nailers

Provide wood nailers when recommended by the manufacturer, when required for fastening flashing or at the edge of the roof assembly. When roof assemblies intersect higher walls including parapets, it is acceptable to secure the roof assembly, when required, to the roof deck without a wood nailer.

2.2.2.2 Size and Type of Wood for Wood Nailers

Use minimum 1½ by 5½ in. (40 by 140 mm) wood nailers of pressure-treated or untreated Douglas Fir, Southern Yellow Pine, or wood having similar decay-resistant properties and specific gravities. The maximum unsupported overhang is 2 in. (50 mm), in which case minimum 1½ by 7¼ in. (38 by 185 mm) nailers are needed, secured with two rows of staggered fasteners.

Flashing should not be nailed or fastened into plywood. Plywood can be used as spacers in the nailer assembly.

2.2.2.3 Securement of Wood Nailers

Fasten wood nailers following Recommendations 2.2.2.3.1 through 2.2.2.3.6, with the fasteners near the end of each section placed between 3 and 4 in. (75 and 100 mm) from the end. Stagger fasteners in two rows when nailers are wider than 6 in. (300 mm). Recommendations are based on minimum 1½ by 5½ in. (40 by 140 mm) wood nailers with ¾ in. deep countersinks for bolts and washers. Other size fasteners and fastener spacings may be acceptable if supported by structural calculations that resist the upward and outward design wind loads on the nailer and nailer substrate, including concrete breakout. Obtain design loads using the RoofNav Calculator and Data Sheet 1-28. Alternate securement for wood nailers should follow ANSI/AWC NDS-2018 ASD/LRFD NDS *National Design Specification for Wood Construction*; TMS 402/602-16, *Building Code Requirements and Specifications for Masonry Structures*, 2016 Edition; or *Building Code Requirements for Structural Concrete (ACI 318-19)*, as appropriate, or comparable local code outside the United States. Reduce the nailer thickness used in calculations by the countersink depth for washers and bolts.

2.2.2.3.1 Fasteners for Wood Nailers

Use corrosion-resistant fasteners that are compatible with the wood nailer. When the wood nailer is treated wood, use stainless steel, hot-dipped galvanized steel complying with ASTM A153 (or equivalent) or fasteners with proprietary coatings recommended by the manufacturer for use in the specific type of treated wood. Bolts should be of sufficient length for all threads in the nuts to be fully engaged.

2.2.2.3.2 Securement of Wood Nailers to Structural Concrete Walls or Reinforced Concrete Masonry Unit Walls

A. Secure wood nailers to structural concrete (see Figure 3.1.1-4) or reinforced concrete masonry unit walls using ½ in. (13 mm) or 3/8 in. (10 mm) steel headed or plate anchor bolts (or threaded rod with a nut at the end) with bolts and washers spaced in accordance with Tables 2.2.2.3.2-1 or 2.2.2.3.2-2. Embed anchor bolts a minimum of 5 in. (300 mm). Countersink bolt holes a maximum of 3/4 in. (20 mm) when 1½ (40 mm) thick wood nailers are used.

For concrete masonry unit (concrete block) walls, embed anchor bolts into a fully grouted concrete bond beam at the top of the wall. Ensure concrete grout is in accordance with ASTM C476-20 (or comparable local standard outside the United States) and is flush with the top of the block. See details in Figures 3.1.1-1 through 3.1.1-3. There should be a continuous vertical load path from the concrete bond beam to the foundation using vertical steel reinforcement spaced a maximum of 10 ft (3.0 m) along the wall installed to *Building Code Requirements and Specifications for Masonry Structures*, 2013 Edition, or comparable local standard outside the United States.

B. When steel framing is continuous directly below the wood nailer (such as where a beam has been installed at the top of the wall, or a steel angle is running parallel to steel deck ribs), the nailer may be bolted to it in accordance with Tables 2.2.2.3.2-1 or 2.2.2.3.2-2. Wood filler blocks may be required. Stagger anchor bolts, in all cases, if the nailer is wider than 6 in. (150 mm).

Table 2.2.2.3.2-1. Maximum Spacing for ½ in. (13 mm) Anchor Bolts Securing Wood Nailers to Structural Concrete or Reinforced Concrete Masonry Unit Walls¹

Minimum Wind Rating for Zone 1	Max. Zone 2 Spacing, in. (mm)	Max. Zone 3 Spacing, in. (mm)
60	48 (1200)	24 (600)
75	48 (1200)	24 (600)
90	48 (1200)	24 (600)
105	48 (1200)	24 (600)
120	48 (1200)	24 (600)
135	48 (1200)	24 (600)
150	36 (900)	24 (600)
165	36 (900)	24 (600)
180	36 (900)	24 (600)
195	36 (900)	24 (600)
210	24 (600)	24 (600)
225	24 (600)	24 (600)
240	24 (600)	12 (300)
255	24 (600)	12 (300)
270	24 (600)	12 (300)

Note 1. For coping or flashing with maximum fascia height of 13 in. (330 mm) and bolt holes countersunk a maximum of 3/4 in. (20 mm) in 1 1/2 (40 mm) thick wood nailers. NOTE: Other sizes and spacings of anchor bolts may be acceptable if supported by structural calculations following Recommendation 2.2.2.3. Reduce nailer thickness in calculations by countersink depth for washers and bolts.

Table 2.2.2.3.2-2. Maximum Spacing for 3/8 in. (10 mm) Anchor Bolts Securing Wood Nailers to Structural Concrete or Reinforced Concrete Masonry Unit Walls¹

Minimum Wind Rating for Zone 1	Max. Zone 2 Spacing, in. (mm)	Max. Zone 3 Spacing, in. (mm)
60	48 (1200)	24 (600)
75	48 (1200)	24 (600)
90	48 (1200)	24 (600)
105	48 (1200)	24 (600)
120	48 (1200)	24 (600)
135	36 (900)	24 (600)
150	36 (900)	24 (600)
165	36 (900)	24 (600)
180	24 (600)	12 (300)
195	24 (600)	12 (300)
210	24 (600)	12 (300)
225	24 (600)	12 (300)
240	24 (600)	12 (300)
255	24 (600)	12 (300)
270	24 (600)	12 (300)

Note 1. For coping or flashing with maximum fascia height of 13 in. (330 mm) and bolt holes countersunk a maximum of 3/4 in. (20 mm) in 1 1/2 (40 mm) thick wood nailers. NOTE: Other sizes and spacings of anchor bolts may be acceptable if supported by structural calculations following Recommendation 2.2.2.3. Reduce nailer thickness in calculations by countersink depth for washers and bolts.

2.2.2.3.3 Securement of Wood Nailers to Secondary Steel Framing

Where wood nailers are secured to secondary steel framing running perpendicular to it (such as when wood nailers are parallel to steel deck ribs) secure as follows:

A. For deck spans 7 ft (2.1 m) or less where the minimum wind rating for Zone 1 is 90 or less, attach wood nailers to each roof joist with one 5/8 in. (16 mm) diameter steel bolt (see Figure 3.1.3-1) in Zone 2 and two 5/8 in. or two ½ in. (16 or 13 mm) diameter steel bolts in Zone 3. Locate joints in lower wood nailers over the steel joists. Larger diameter bolts should not be used unless calculations are provided by a structural engineer because the thicker bolts and washers for larger diameter bolts reduce the nailer thickness after countersinking, resulting in a weaker connection.

B. For deck spans longer than 7 ft (2.1 m), or where the minimum wind rating for Zone 1 exceeds 90, secure a steel angle to the structure below the nailer and attach the nailer to the angle in accordance with Recommendation 2.2.2.3.2 using Table 2.2.2.3.2-1 or 2.2.2.3.2-2. Structural framing used to secure the anchor bolts should be designed to resist the design loads in Recommendation 2.2.2.3.

2.2.2.3.4 Securement of Wood Nailers to Steel Decks

Where wood nailers are secured to minimum 22 ga. (0.0295 in.; 0.75 mm) steel decks, use any fastener that is FM Approved for the securement of above-deck roof components to steel decks. Provide two staggered rows of fasteners with a maximum fastener spacing within each row in accordance with Table 2.2.2.3.4-1. Fasten into the top flange of the steel deck with fasteners of sufficient length to protrude ¾ in. (19 mm) below the steel deck. For details see Figures 3.1.3-2 Multi-ply roof cover with panel wall with roof edge cant, nailer screwed to roof deck and 3.1.3-3 Multi-ply roof with panel wall with roof edge cant, nailer screwed to deck. Prior to installing the wood nailers, secure the steel deck to joists or purlins in accordance with Data Sheet 1-29, *Roof Deck Securement and Above-Deck Roof Components*.

Do not install wood nailers to steel decks that overhang the supporting beam unless the outer extremity of the deck or nailer is secured from vertical deflection by attachment to the roof joists or wall.

Table 2.2.2.3.4-1. Maximum Spacing Within Each Row (2 rows required) for Fasteners Securing Wood Nailers to Structural Concrete Decks or Minimum 22 ga. (0.0295 in. [0.75 mm]) Steel Decks¹

Minimum Wind Rating for Zone 1	Max. Zone 2 Spacing, in. (mm)	Max. Zone 3 Spacing, in. (mm)
60	24 (600)	24 (600)
75	24 (600)	24 (600)
90	24 (600)	24 (600)
105	24 (600)	24 (600)
120	24 (600)	24 (600)
135	24 (600)	24 (600)
150	24 (600)	24 (600)
165	24 (600)	18 (500)
180	24 (600)	18 (500)
195	24 (600)	18 (500)
210	24 (600)	18 (500)
225	18 (500)	12 (300)
240	18 (500)	12 (300)
255	18 (500)	12 (300)
270	18 (500)	12 (300)

Note 1. Maximum fascia height of 13 in. (330 mm). NOTE: Other sizes and spacing's of fasteners may be acceptable if supported by structural calculations following Recommendation 2.2.2.3.

2.2.2.3.5 Securement of Wood Nailers to Structural Concrete Decks

Where wood nailers are secured to structural concrete decks with a minimum compressive strength f_c of 2500 psi (17,000 kPa), use any fastener that is FM Approved for securing above-deck roof components to structural concrete decks. Provide two staggered rows of fasteners with maximum fastener spacing within each row in accordance with Table 2.2.2.3.4-1. Provide a minimum of 1 in. (25 mm) embedment into the concrete. Wood nailers should not be anchored to lightweight insulating concrete (LWIC).

2.2.2.3.6 Securement of Wood Members to Wood Nailers

Secure wood members, such as fascias, cant strips, and top nailers, up to 8 in. (200 mm) wide to lower wood nailers using minimum 10d (penny) (3 in., 75 mm) long common (smooth shank) nails or minimum no. 8 (4 mm dia.) screws in two staggered rows. The maximum fastener spacing within each row should be in accordance with Table 2.2.2.3.6-1 with nails or fasteners long enough to penetrate 1-1/2 in. (40 mm) into the lower wood nailer. Other fasteners with a minimum design withdrawal resistance of 60 lb (27 kg) using ANSI/AWC NDS-2012 *National Design Specification for Wood Construction* or equivalent local standard. This securement method is acceptable for a maximum of two (2) top wood nailers secured to the bottom wood nailer. Other configurations should be designed by a structural engineer.

Table 2.2.2.3.6-1. Maximum Spacing Within Each Row (2 Rows Required) for Fasteners Securing Wood Members to Wood Nailers¹

Minimum Wind Rating for Zone 1	Max. Zone 2 Spacing, in. (mm)	Max. Zone 3 Spacing, in. (mm)
60	24 (600)	12 (300)
75	24 (600)	12 (300)
90	24 (600)	12 (300)
105	24 (600)	12 (300)
120	22 (560)	12 (300)
135	20 (510)	12 (300)
150	18 (500)	12 (300)
165	16 (400)	10 (250)
180	14 (360)	10 (250)
195	14 (360)	8(200)
210	12 (300)	8(200)
225	12 (300)	8(200)
240	10(250)	6(150)
255	10(250)	6(150)
270	10(250)	6(150)

Note 1. Maximum fascia height of 13 in. (330 mm) and maximum 8 in. (200 mm) wide wood members. NOTE: Other sizes and spacings may be acceptable if supported by structural calculations following Rec. 2.2.2.3.

2.2.3 Cant Strips

Provide wood cant strips if required by the manufacturer or if the flashing assembly or roof cover is screwed or nailed into the cant strip. Otherwise non-wood cant strips can be used. Non-wood cant strips should be of a material that is in an FM Approved assembly in which the roof cover is adhered to it. Secure in accordance with Recommendation 2.2.2.3.6.

2.2.4 Base Securement of Adhered Single-Ply Membranes with Reinforced Membrane Attachment Strips

This section applies to reinforced membrane attachment strips (RMAS) that are mechanically fastened (not adhered to insulation or coverboard) and used for base securement of fully adhered single-ply membranes where roof assemblies intersect higher walls including parapets.

2.2.4.1 Use RMAS with seam tape that is either factory- or field-applied after using field primer on the roof cover per the manufacturer's instructions. Splicing cement is not recommended because seam tape provides additional stiffness that improves wind uplift resistance.

2.2.4.2 Fasten RMAS in accordance with the manufacturer's instructions using FM Approved batten bars or stress plates and FM Approved fasteners to the nailer, deck, or wall as follows (see details in Figures 2.2.4.2.1-1, 3.2.7-1, and 3.2.7-2):

A. Fasten maximum 12 in. (300 mm) in Zone 2 and 6 in. (150 mm) in Zone 3 where a minimum Zone 1 rating of 90 or less is needed. Fasten 12 in. (300 mm) in Zone 3 if there is a minimum 3 ft (900 mm) high continuous parapet around the entire roof.

B. Fasten maximum 6 in. (150 mm) in Zone 2 and 4 in. (100 mm) in Zone 3 where a Zone 1 rating of 105 or greater is needed. Fasten 6 in. (150 mm) in Zone 3 if there is a minimum 3 ft (900 mm) high continuous parapet around the entire roof.

2.2.4.2.1 Locate fasteners and stress plates inward from the wall or parapet to the maximum tolerance allowed by the manufacturer from the edge of the RMAS (as close to the seam tape as allowed) to reduce the unadhered section of the RMAS that cantilevers over the insulation board. See Figure 2.2.4.2.1-1.

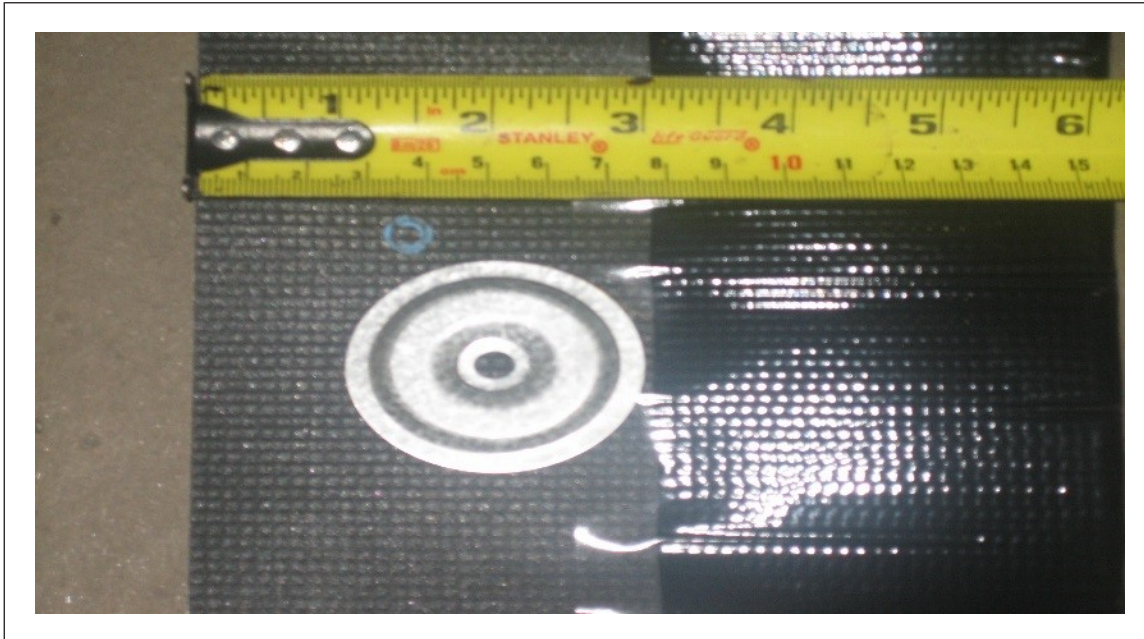

Fig. 2.2.4.2.1-1. Reinforced membrane attachment strip with stress plate approximately 1 in. (25 mm) from edge

2.2.5 Mechanical Fastening for Single-Ply Membranes Adhered to Walls or Parapets above Roof Assemblies

Provide mechanical fastening for single-ply membranes adhered to walls or parapets in accordance with the manufacturer's instructions and designed to resist the zone 4 and 5 wind pressures. Fastening consists of one or more rows, usually horizontal, of batten bars, stress plates, or reinforced membrane attachment strips with fasteners securing the membrane to the wall. (Many roofing manufacturers recommend mechanical fastening of single-ply membranes adhered to walls when the height on the wall of the adhered membrane exceeds 4 or 5 ft [1.2 to 1.5 m]). See reinforced membrane attachment strip in Figure 2.2.4.2.1-1.

When guidance is not provided, install equally spaced horizontal or vertical rows of FM Approved batten bars, stress plates, or reinforced membrane attachment strips with fasteners with a maximum spacing between rows of 5 ft (1.5 m) as follows:

- A. When the minimum recommended Zone 1 rating is 90 or less, space fasteners a maximum of 12 in. (300 mm).
- B. When the minimum recommended Zone 1 rating is 105 or higher, space fasteners a maximum of 6 in. (150 mm).

2.2.6 Metal Counter-Flashing

Size metal counter-flashing in accordance with Table 2.2.6-1 (or 2.2.6-2 for metric) and secure in accordance with the roofing manufacturer but not less than as recommended below. Other size counter-flashing and securement that have been tested or designed by a licensed structural engineer can be used. They should resist the horizontal pressures in Table 3.4-1 (which include a safety factor of 2) for the applicable Zone 1 roof rating. (Currently there are no FM Approved counter-flashings.)

- A. When secured directly to concrete or masonry walls, use metal anchors (no plastic materials) spaced a maximum of 12 in. (300 mm) along Zone 2 (see Figure 3.1.2-1) and a maximum 6 in. (150 mm) in Zone 3. The anchors should be at least 1 in. (25 mm) below the top edge of the felt base flashing and should penetrate the wall at least 1 in. (25 mm). Typical 1/4 in. (6 mm) diameter fasteners should provide acceptable pullout resistance. For smaller diameters or lesser embedment, the manufacturer should verify that a minimum ultimate pull-out resistance of 200 lb (91 kg) per fastener is provided.
- B. When secured on the interior side of the wall to wood nailers, use minimum No. 10 (5 mm) galvanized screw fasteners with bonded sealing washers spaced a maximum of 12 in. (300 mm) along Zone 2 and a maximum of 6 in. (150 mm) in Zone 3 and long enough to penetrate the wood 1 in. (25 mm) (see Figure 3.1.4-1). For counter-flashing on fire walls, also see Recommendation 2.2.7.

Table 2.2.6-1. Maximum Counter-Flashing Height (“L” Dimension in Figures) and Metal Thicknesses (in.)

Type of Metal	Maximum Counter-Flashing Height (in.)															
Minimum Wind Rating Zone 1	60	75 & 90	105	120	135	150	165	180	195	210	225	240	255	270		
Galv. Steel or Stainless Steel																
Ga.	(mm)	in.	in.	in.	in.	in.	in.	in.	in.	in.	in.	in.	in.	in.	in.	in.
26	(0.45)	6	6	4	4	4	4	4	n/a	n/a	n/a	n/a	n/a	n/a	n/a	n/a
24	(0.61)	8	8	6	6	6	6	6	4	4	4	3	3	3	3	3
22	(0.76)	10	10	8	8	8	8	8	5	5	5	5	5	4	4	4
20	(0.91)	12	12	10	10	10	10	10	7	7	6	6	6	6	5	5
Aluminum ¹																
in.	(mm)	in.	in.	in.	in.	in.	in.	in.	in.	in.	in.	in.	in.	in.	in.	in.
0.032	(0.80)	3	3	3	3	3	3	3	n/a	n/a	n/a	n/a	n/a	n/a	n/a	n/a
0.040	(1.02)	6	6	4	4	4	4	4	n/a	n/a	n/a	n/a	n/a	n/a	n/a	n/a
0.050	(1.27)	8	8	6	6	6	6	6	4	4	4	3	3	3	3	3
0.060	(1.62)	10	10	8	8	8	8	8	5	5	5	5	5	4	4	4
0.070	(1.78)	10	10	10	10	10	10	10	7	7	6	6	6	6	5	5
Copper																
oz	(mm)	in.	in.	in.	in.	in.	in.	in.	in.	in.	in.	in.	in.	in.	in.	in.
16	(0.55)	8	6	4	3.5	3.5	3.5	3.5	n/a	n/a	n/a	n/a	n/a	n/a	n/a	n/a
20	(0.69)	10	8	6	6	6	6	6	4	4	4	3	3	3	3	3
24	(0.82)	10	10	8	8	8	8	8	5	5	5	5	5	4	4	4
32	(1.10)	10	10	10	10	10	10	10	7	7	6	6	6	6	5	5

Note 1. Temper “O” aluminum, although easily formed, has a low bending strength. High tempers are advised when using aluminum.
 Note 2. “n/a” = not applicable; use thicker metal.

Table 2.2.6-2. Maximum Counter-Flashing Height (“L” in Figures) and Metal Thicknesses (mm)

Type of Metal	Maximum Counter-Flashing Height(mm)															
Minimum Wind Rating Zone 1	60	75 & 90	105	120	135	150	165	180	195	210	225	240	255	270		
Galv. Steel or Stainless Steel																
Ga.	(mm)	mm	mm	mm	mm	mm	mm	mm	mm	mm	mm	mm	mm	mm	mm	mm
26	(0.45)	150	150	100	100	100	100	100	n/a	n/a	n/a	n/a	n/a	n/a	n/a	n/a
24	(0.61)	200	200	150	150	150	150	150	100	100	100	75	75	75	75	75
22	(0.76)	250	250	200	200	200	200	200	125	125	125	125	125	100	100	100
20	(0.91)	300	300	250	250	250	250	250	175	175	150	150	150	150	125	125
Aluminum ¹																
in.	(mm)	mm	mm	mm	mm	mm	mm	mm	mm	mm	mm	mm	mm	mm	mm	mm
0.032	(0.81)	75	75	75	75	75	75	75	n/a	n/a	n/a	n/a	n/a	n/a	n/a	n/a
0.040	(1.02)	150	150	100	100	100	100	100	n/a	n/a	n/a	n/a	n/a	n/a	n/a	n/a
0.050	(1.27)	200	200	150	150	150	150	150	100	100	100	75	75	75	75	75
0.060	(1.62)	250	250	200	200	200	200	200	125	125	125	125	125	100	100	100
0.070	(1.78)	250	250	250	250	250	250	250	175	175	150	150	150	150	125	125
Copper																
oz	(mm)	mm	mm	mm	mm	mm	mm	mm	mm	mm	mm	mm	mm	mm	mm	mm
16	(0.55)	200	150	100	90	90	90	90	n/a	n/a	n/a	n/a	n/a	n/a	n/a	n/a
20	(0.69)	250	200	150	150	150	150	150	100	100	100	75	75	75	75	75
24	(0.82)	250	250	200	200	200	200	200	125	125	125	125	125	100	100	100
32	(1.10)	250	250	250	250	250	250	250	175	175	150	150	150	150	125	125

Note 1. Temper “O” aluminum, although easily formed, has a low bending strength. High tempers are advised when using aluminum.
 Note 2. “n/a” = not applicable; use thicker metal.

2.2.7 Flashing Systems at MFL Fire Walls

Refer to DS 1-42, *Maximum Foreseeable Loss Limiting Factors*, for flashing systems at MFL walls.

2.2.8 Securing Flashing to Existing Metal Panel Walls

For existing buildings, secure the vertical section of loose flashing directly to metal panel walls when a hook strip is not present, and it would be difficult to install one. Use minimum No. 10 (4.8 mm) galvanized sheet metal screws, with bonded sealing washers, spaced in accordance with Table 2.2.8-1.

Table 2.2.8-1. Maximum Fastener Spacing for Flashing Secured Directly to Existing Metal Panel Walls

Wind Rating for Zone 1	Maximum Zone 2 Spacing, in. (mm)	Maximum Zone 3 Spacing, in. (mm)
60	24 (600)	16 (400)
90	16 (400)	10 (250)
120	12 (300)	6 (150)
150	10 (250)	6 (150)
195	8 (200)	6 (150)
990	6 (150)	4(200)

2.2.9 Sealing Spaces between Walls and Roofs

Seal spaces between the walls and roof near the roof eave. For more information, see Section 3.1.3.

2.2.10 Gutter Systems Gravity Load

When FM Approved gutter systems are not available, design gutter systems to support the gravity load when full of water and provide a watertight seal between gutters and the underside of the roof per Data Sheet 1-54, *Roof Loads and Drainage*.

FM Approved gutters are tested for gravity load when full of water.

2.2.11 Roof Drainage

Provide primary and secondary roof drainage in accordance with DS 1-54, *Roof Loads and Drainage*. Where rainwater spilling over the top of a gravel stop is the intended method for secondary roof drainage, the height of the gravel stop should not exceed the maximum height of ponded water that the roof can support considering roof deflection under load. Where parapet walls are provided, and wall scuppers are used for primary or secondary drainage, the size and location of the wall scuppers should also consider the maximum height of ponded water that the roof can support considering roof deflection under load. In either case, these details should be coordinated with the structural engineer.

2.2.12 Flashing Systems and Roof-Mounted Photovoltaic Panels

Refer to Data Sheet 1-15 if there are roof-mounted photovoltaic panels.

2.3 Operation and Maintenance

2.3.1 Inspect the roof flashing system, including base tie-ins and strip-in plies that seal with the roof cover, and the roof assembly, drains and roof-mounted equipment at least semiannually and before and after storms with high winds, heavy rain or hail. Refer to Data Sheet 1-32, *Inspection and Maintenance of Roof Assemblies*.

The strip-in felts for metal gravel guards will likely require periodic maintenance because the joints, which depend on the plastic roofing cement to remain tight, are likely to break open at every second or third joint due to expansion and contraction of the metal. If tapered insulation is used to raise the edge out of the water line in the case of flat roofs, or if the roof slopes away from the roof edge, the problems are somewhat minimized, but still exist.

Replace rusted or missing sections of flashing and secure loose flashing by fastening it through the lower 1/3 of the flashing using corrosion resistant fasteners with bonded sealing washers as follows:

- A. Securement to wood nailer: minimum No. 8 (4.2 mm dia.) screws spaced per Table 2.3.1-1 with $\frac{3}{4}$ in. (19 mm) minimum embedment. When treated wood is present, see recommendation 2.2.1.2.
- B. Securement to metal panel walls: minimum No. 10 (4.8 mm dia.) sheet metal screws spaced per Table 2.2.8-1.
- C. Securement to concrete or masonry construction without a nailer: pre-drilling and use of masonry anchors, such as fasteners FM Approved for concrete decks spaced per Table 2.3.1-1 with minimum 1 in. (25 mm) embedment.

Table 2.3.1-1. Maximum Fastener Spacing to Secure Loose Flashing to wood and masonry

Maximum Wind rating for Zone 1	Maximum Zone 2 Spacing in. (mm)	Maximum Zone 3 Spacing in. (mm)
60	24 (600)	16 (400)
90	16 (400)	10 (250)
990	12 (300)	6 (150)

2.3.2 Replace rotted wood nailers or corroded fasteners during re-roofing or re-cover installations, or at any other time deterioration is noticed. Fasten replacement wood nailers in accordance with Section 2.2.2.3 using fasteners for existing structural concrete or concrete masonry unit walls since cast-in-place anchors cannot be used. Securing to existing unreinforced concrete masonry unit walls is acceptable if the existing anchors are secure in the grout and there are no separations in the horizontal mortar joints within the top five courses of concrete masonry units. If there are separations, have a structural engineer inspect them, develop a repair plan if needed, and design nailer securement using metal hardware and anchors into a lower area on the wall. See Section 2.2.2.3 for design loads and guidelines with uplift resistance provided by the weight of the wall above the lower anchors using a safety factor of 1.5.



Fig. 2.3.2-1. Existing perimeter flashing secured at its lower edge

3.0 SUPPORT FOR RECOMMENDATIONS

This section provides support for the recommendations in Section 2.0. Flashing to roof membrane connection details should follow the manufacturer's instructions. See Figures 3.1.1-1 through 3.2.7-2, and the *National Roofing Contractors Association's Roofing Manual: Membrane Roof Systems* for additional guidance.

Metal sections used for perimeter flashing are usually 8-10 ft (2.44-3.05 m) long. A space is left between sections to allow for expansion of the metal. The joint may be closed with a cover plate of the same metal or another joint treatment may be preferred. Follow the manufacturer's instructions.

3.1 Flashing Details for Multi-Ply Roof Covers

3.1.1 Masonry Wall with Roof Edge Cant with Multi-Ply Roof Cover

Figures 3.1.1-1 through 3.1.1-4 show details for masonry walls with roof edge cant flashing with multi-ply roof covers. In Figures 3.1.1-1 and 3.1.1-2, the bottom nailer may be anchored by placing the bolts at the necessary depth into the reinforced concrete bond beam at the top of the concrete masonry unit wall (see Recommendation 2.2.2.3.2). In Figure 3.1.1-3, the nailer above the wall can be secured by steel rods welded to a steel angle that is welded to anchor bolts embedded into the reinforced concrete bond beam.

See Section 2.0 for recommendations for anchoring the following components:

- Wood nailers to reinforced concrete or concrete masonry unit (CMU) walls (Recommendation 2.2.2.3.2)
- Wood nailers to steel framing or deck (Recommendation 2.2.2.3.3 or 2.2.2.3.4)
- Wood members to wood nailers (Recommendation 2.2.2.3.6)
- Metal counter-flashing (Recommendation 2.2.6.)

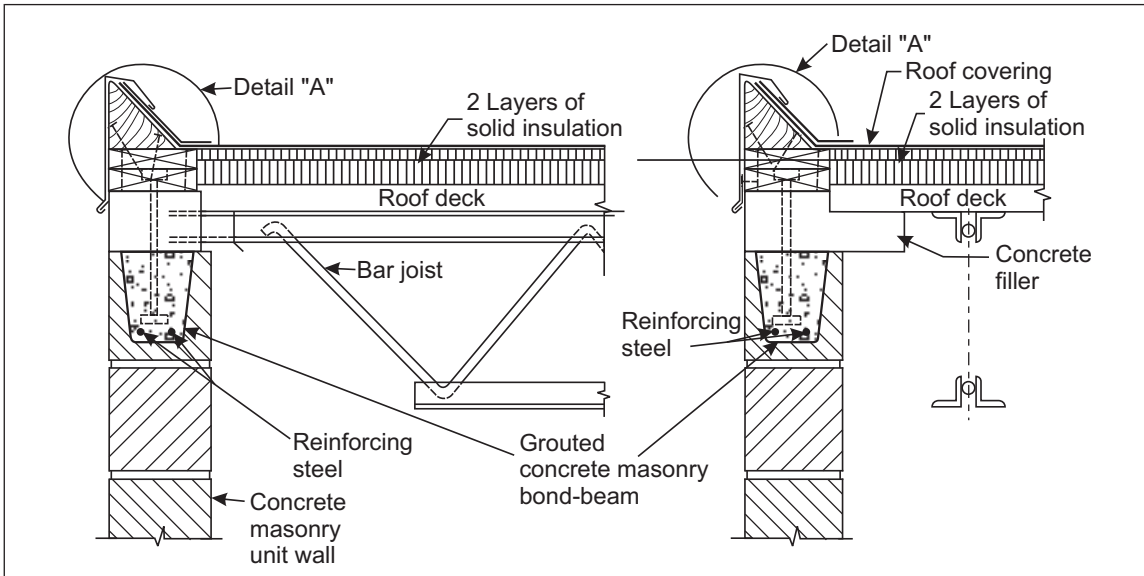

Fig. 3.1.1-1. Multi-ply roof cover with perimeter edge flashing detail

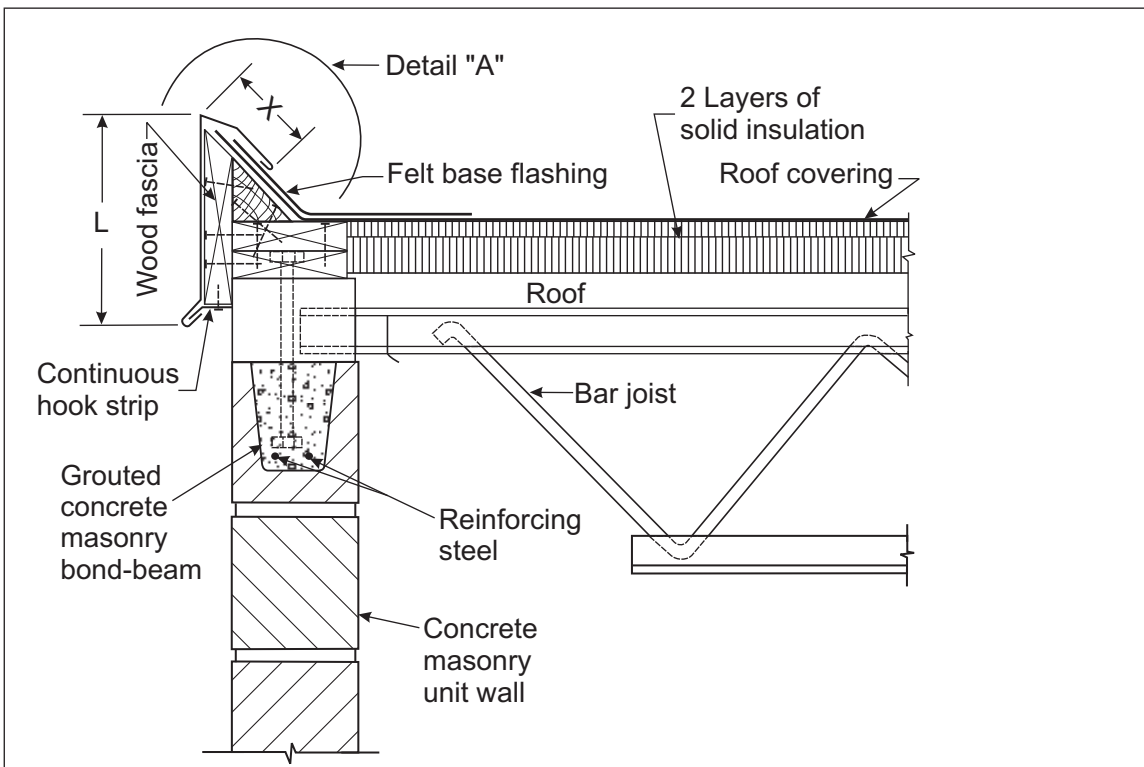

Fig. 3.1.1-2. Multi-ply roof cover with roof edge cant and wood fascia

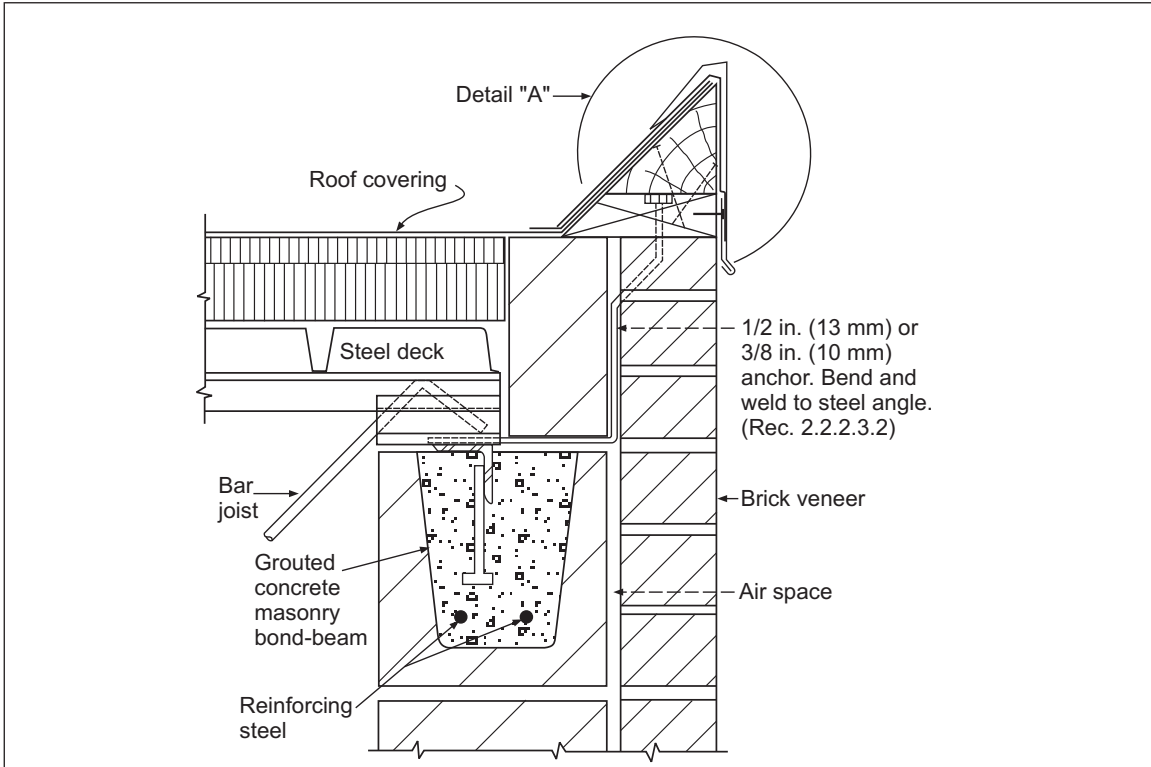

Fig. 3.1.1-3. Multi-ply roof cover with roof edge fascia cap (cant) flashing

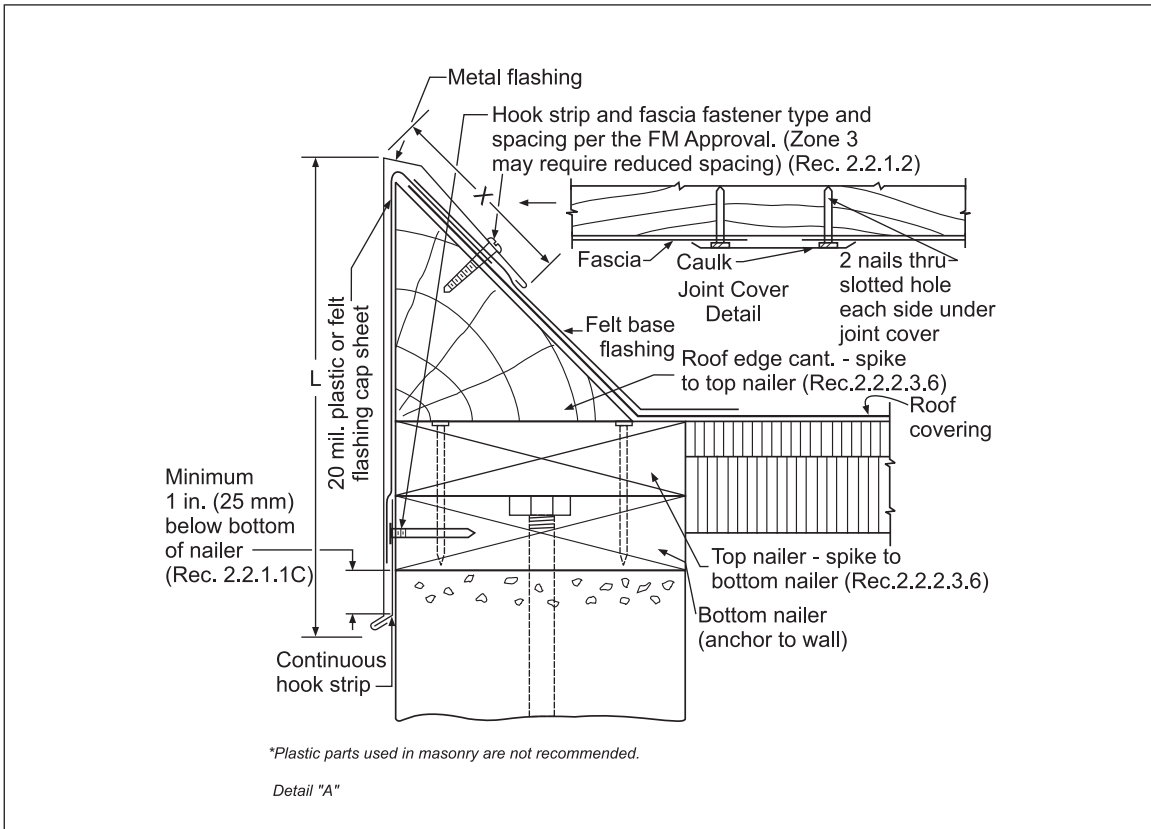

Fig. 3.1.1-4. Detail A from Figure 3.1.1-3

3.1.2 Masonry Wall with High Parapet and Multi-Ply Roof Cover

Figure 3.1.2-1 shows flashing details for masonry walls with high parapets, or where a roof meets the wall of a higher building.

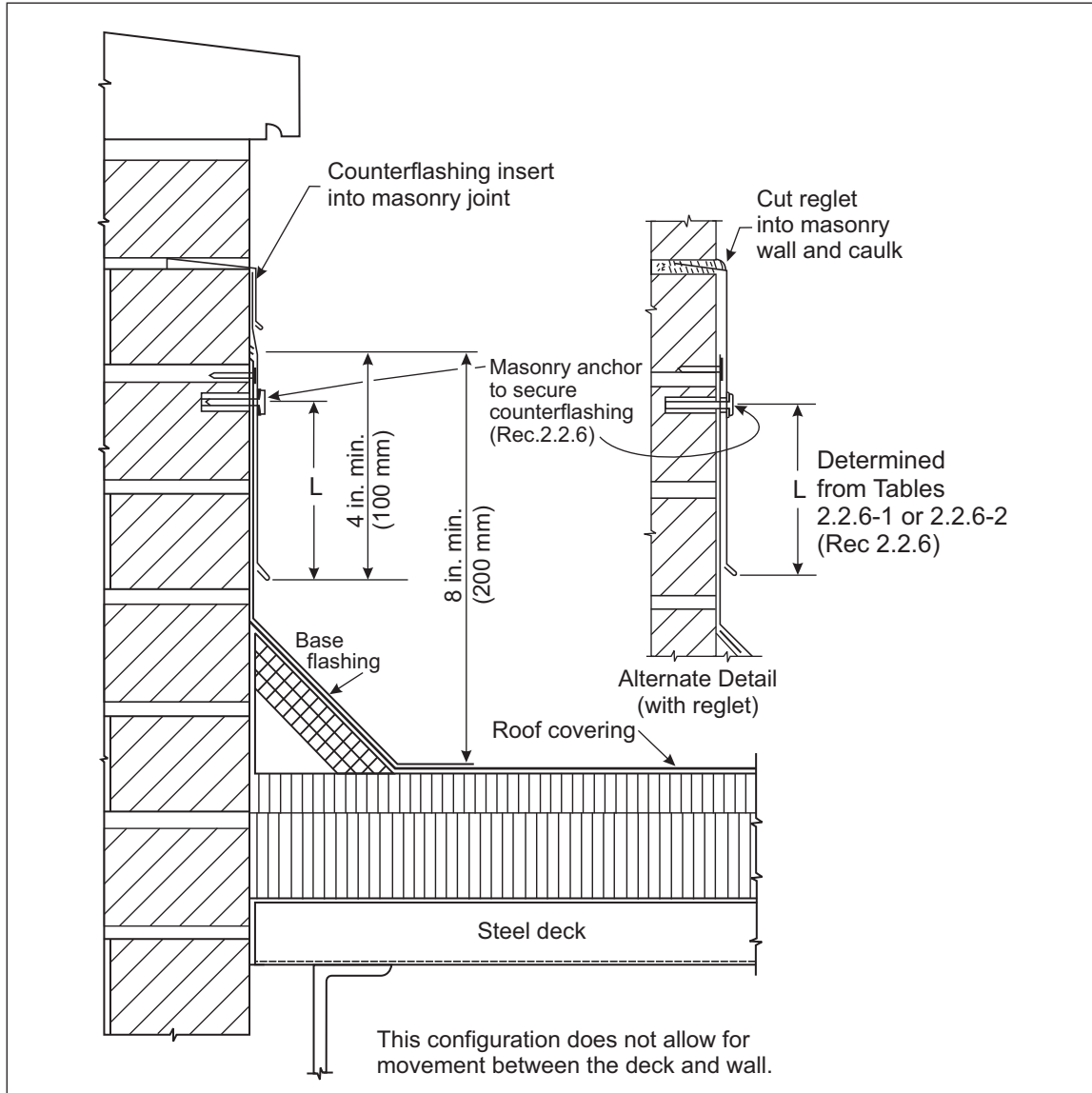

Fig. 3.1.2-1. Multi-ply roof cover with masonry wall with high parapet

The roofing membrane and base flashing should be applied in accordance with the roofing manufacturer's specifications, and secured at the top edge with masonry nails. The top edge of felt base flashing should be sealed with plastic cement.

The metal counter-flashing, sized and secured in accordance with recommendation 2.2.6, should be slipped under the counter-flashing insert and over the felt base flashing. For attachment of the metal, first drill holes into which the masonry anchors are inserted. Resistance is provided by expansion sleeves or threads on the anchor.

Note: Plastic parts used in masonry anchors are not recommended.

A reglet approximately 1 in. (25 mm) deep also may be cut into the wall. The reglet is primed and filled with a high grade caulking compound. The counterflashing is then inserted into the reglet and secured with masonry anchors spaced in accordance with the manufacturer's guidelines but with a 12 in. (300 mm) maximum spacing.

When the parapet is too low for an insert or reglet on the vertical surface, the wall top can be covered with a metal coping. (See Figure 3.2.3-3.)

3.1.3 Cantilevered Wood Nailers

Nailers can sometimes be cantilevered (overhanging) roof deck to meet the outer face of the wall (see Figure 3.1.3-1). If the wall is farther away, the nailers can extend only to the inner face of the wall (see Figures 3.1.3-2 and 3.1.3-3).

Blocking, or several thicknesses of wood may be necessary so that the top of the nailer will be level with the top of the roof insulation or top of the deck (if no insulation is used).

When the wall is constructed of precast concrete, bolts are usually cast in the top edge of the wall to anchor the nailer. The threaded bolt is projected upward sufficient distance so that the tops of the nuts and bolts are even with the top of the nailer. It is necessary to countersink the nut into the wood.

When the roof deck is a heavy, poured-concrete slab, it may be cantilevered to the wall edge without beam support. The nailer may then be bolted directly to the concrete.

When the walls of the building are ribbed, an insulated metal closure normally is provided behind the hook strip. This also prevents wind from getting behind the metal fascia and bending it outward.

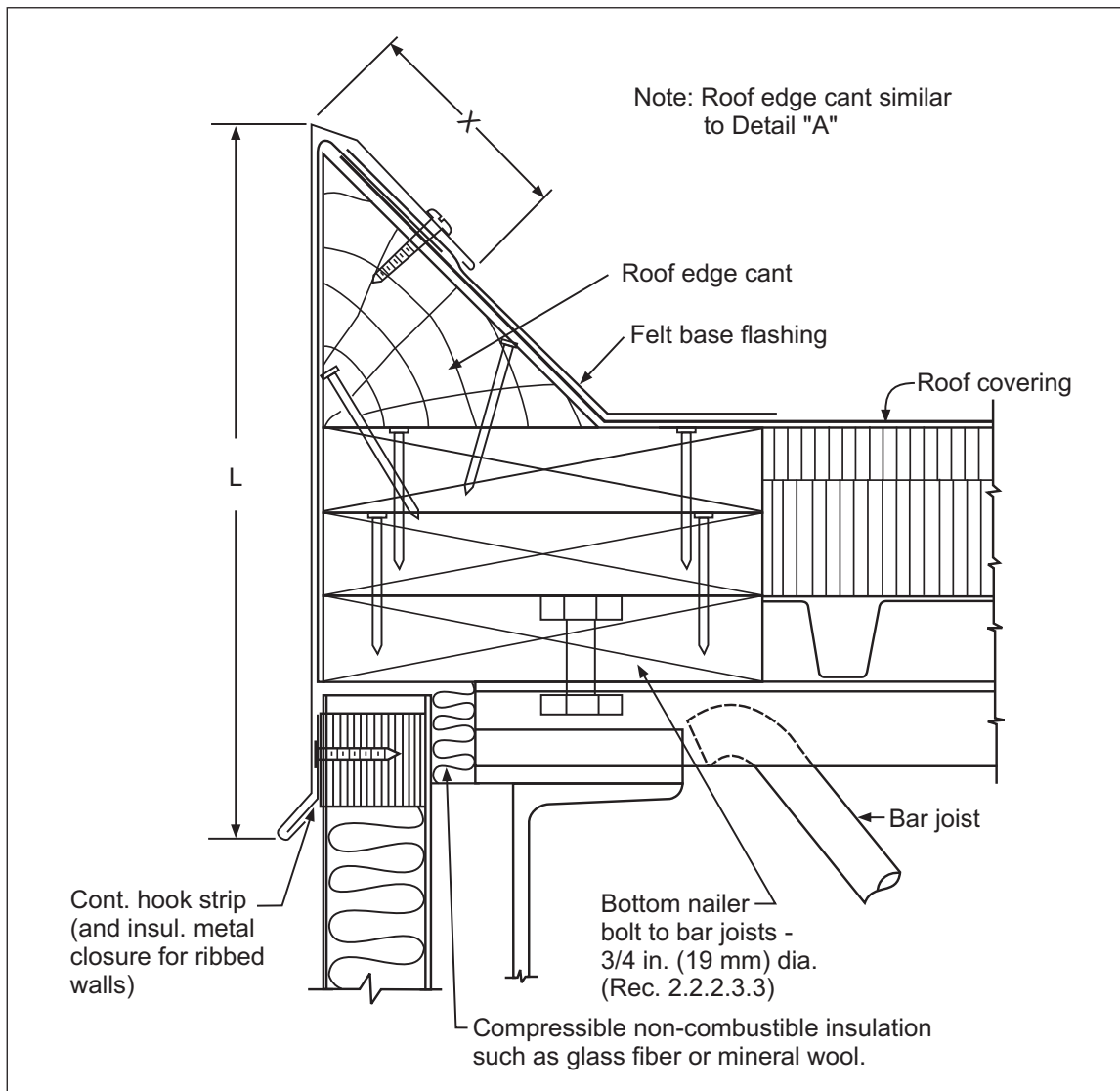

Fig. 3.1.3-1. Multi-ply roof with panel wall with roof edge cant, nailer bolted to roof joists

3.1.4 Panel Wall With Parapet and Multi-Ply Roof Cover

Should the panel wall extend above the roof, forming a parapet, a good installation may be obtained by bolting a wood nailer to the inner face of the wall. The coping and combination counter-flashing may be attached to this nailer and to the outer face of the wall. The bottom nailer may be attached directly to the steel deck, as the outside extremity is held from vertical deflection by the wood members above. A closure and hook strip are provided on the outside. Walls to which flashing assemblies are attached should be independently supported by the building frame and should not create a stress on the flashing assembly (see Figure 3.1.4-1).

3.1.5 Metal Gravel Guards and Fascias

Metal gravel guards, fascias, and hook strips for these are typically not heavier than 24-26-gauge (0.61-0.45 mm) galvanized steel or stainless steel, 16-12 oz (0.55-0.41 mm) copper or 0.040-0.30 in. (1.02-0.77 mm) aluminum in 8 to 10 ft (2.4 to 3.0 m) lengths because thermal expansion and contraction in heavy gauge metal can sometimes dislodge the fasteners in gravel guards. They are lapped a minimum of 2 in. (50 mm) at their joints. A full bead of plastic roofing cement is between the lap or space ends and a 4 in. (102 mm) wide cover plate. The roof flange (horizontal part) is set over all the roofing felts in a solid trowel coat of plastic roofing cement and nailed 1 in. (25 mm) from the back edge at 4 in. (100 mm) spacing. The flange edge and nail

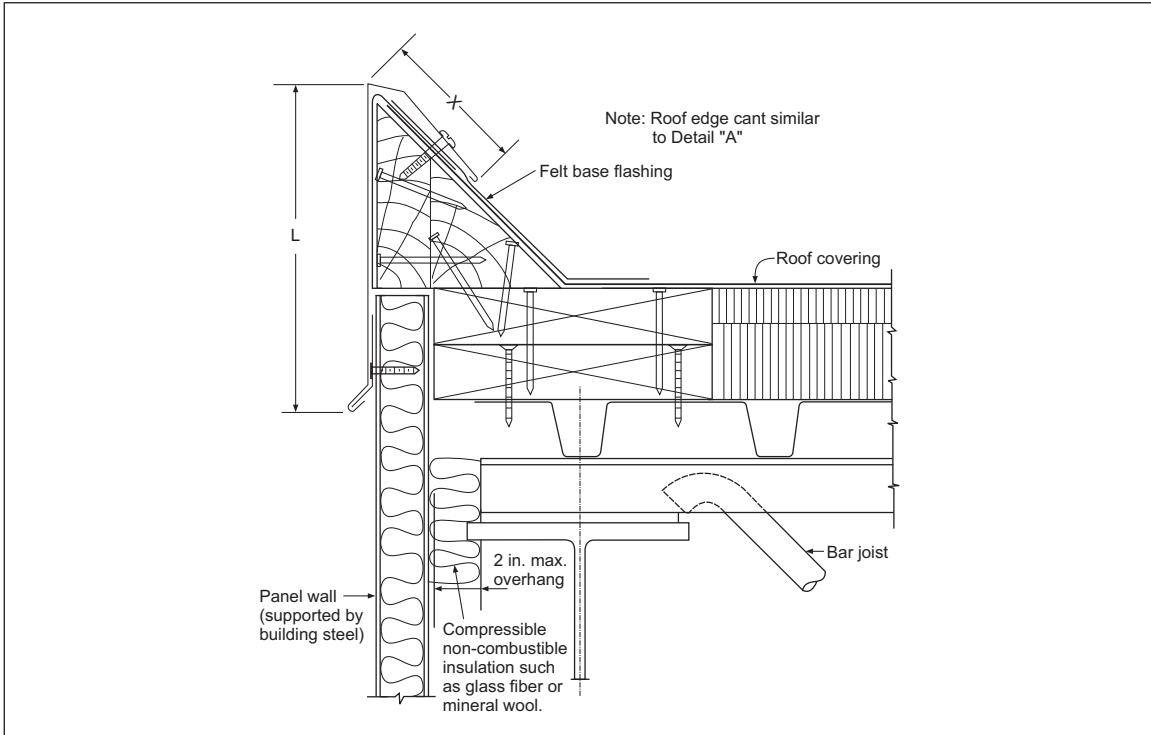

Fig. 3.1.3-2. Multi-ply roof cover with panel wall with roof edge cant, nailer screwed to roof deck

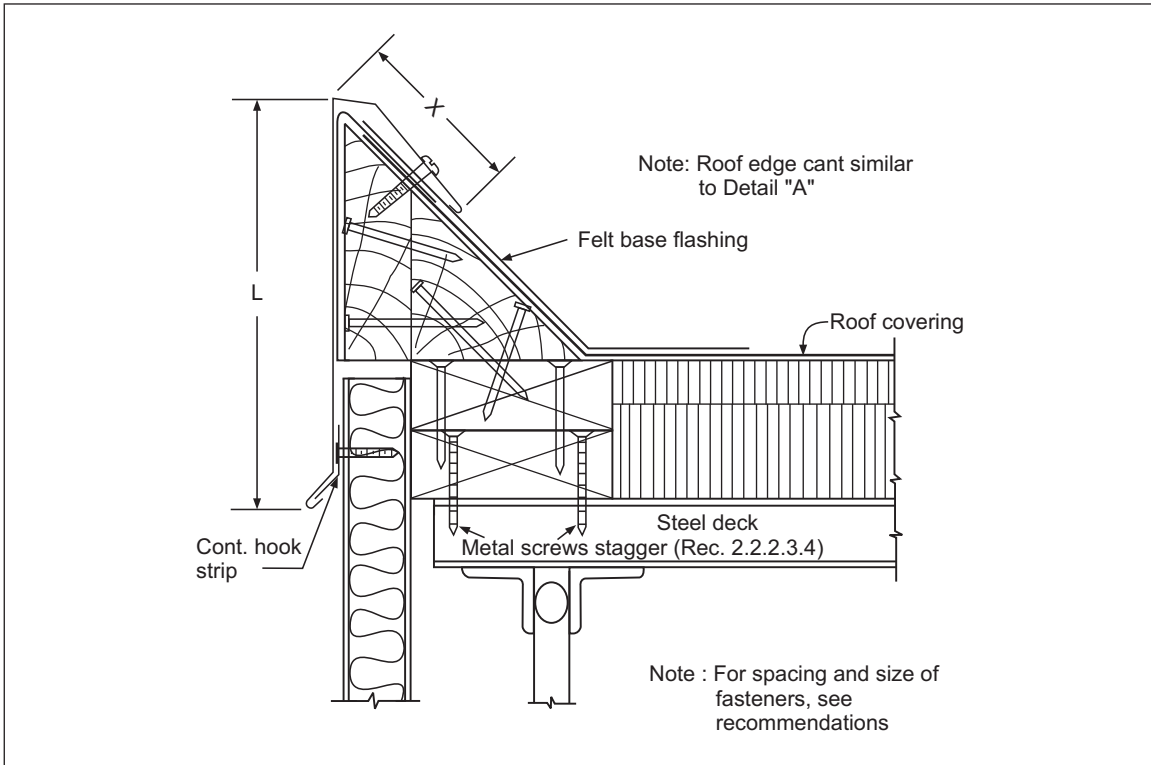

Fig. 3.1.3-3. Multi-ply roof with panel wall with roof edge cant, nailer screwed to deck

heads are sealed by stripping in with two layers of felt set in hot roofing bitumen. The first 6 in. (150 mm) wide strip should extend onto the gravel guard flange 3 in. (75 mm), overlapping the nail heads 2 in. (50 mm),

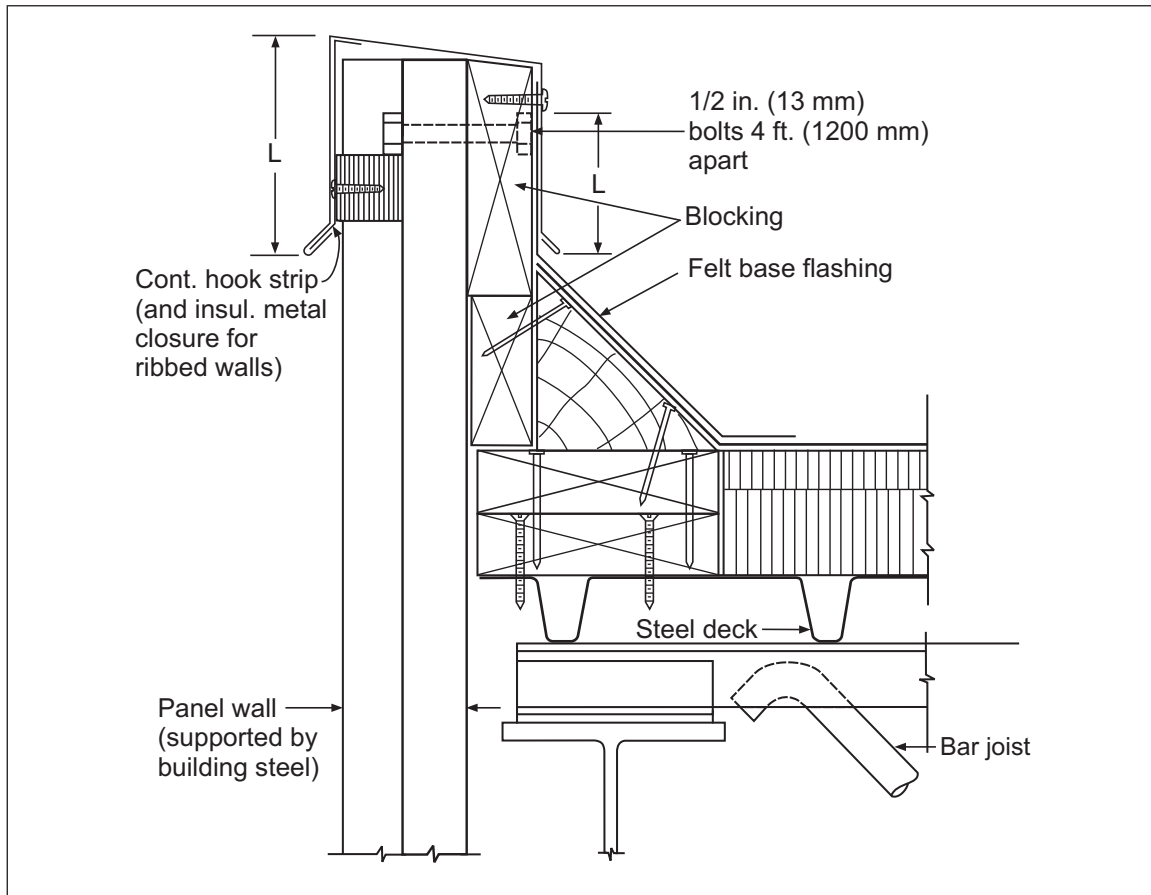

Fig. 3.1.4-1. Panel wall with parapet and multi-ply roof cover

and over the roofing felts 3 in. (75 mm). A second strip 9 in. (230 mm) wide is extended onto the gravel guard flange to the gravel stop at least 4 in. (100 mm) and over the roofing felts a minimum of 4 in. (100 mm). It is important that the second layer have a good overlap on the metal flange beyond the first layer (Figure 3.1.5-1).

3.1.6 Gutters

Wind can remove weakly attached gutters, leading to failure of the roof cover. This is often due to neglecting the wind forces while designing gutters, with the design based only on the gravity load. Follow recommendation 2.2.1.3 to provide FM Approved gutters or FM Approved flashing with gutters when gutters with the proper wind rating are not available. See Figure 3.1.6-1.

Rain water entering the building through the tops of walls at their junction with the roof is very common in Europe. This is common with sloped roofs that have gutters and downspouts. Gutters and/or downspouts can get obstructed with hail, leaves or debris. This allows rainwater to back up within the gutters and enter the building through unprotected openings.

3.2 Single-Ply Membrane (SPM) Flashing Details

3.2.1 General

When single-ply membranes are used, special adhesives or laminations are used for attachment and sealing to the metal. Otherwise, items specified in multi-ply roof Flashing Details can be used.

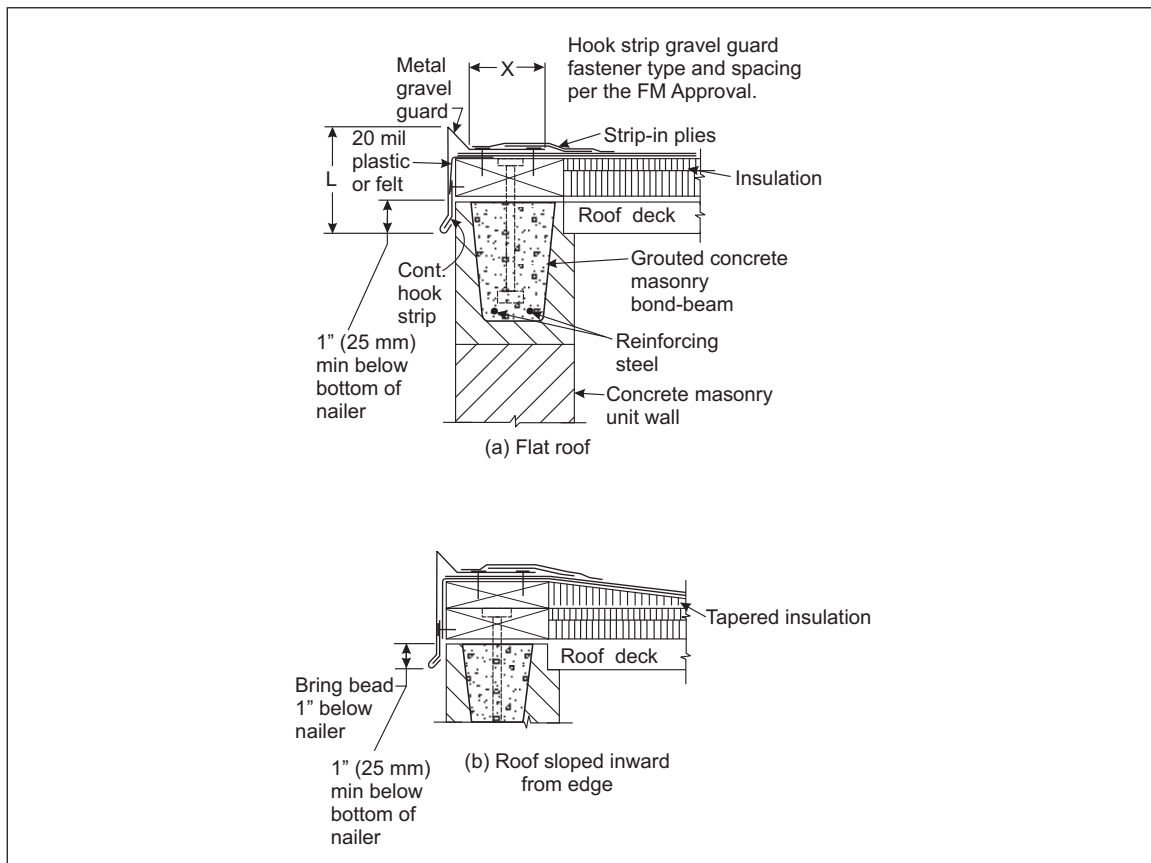

Fig. 3.1.5-1. Metal gravel guard fascia flashing

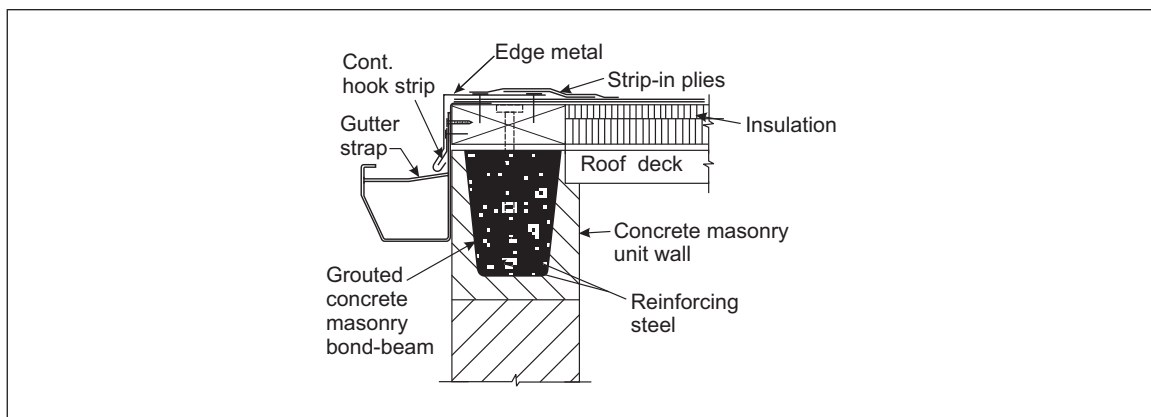

Fig. 3.1.6-1 Metal gutter with fascia flashing

3.2.2 Membrane Terminations

The membrane should be continuous across the junction between the wall and roof, otherwise water will enter the building. When the roof edge has a gravel guard or drip (draining) edge fascia, the membrane, if flexible, can be extended down over the nailers and fastened (see Figures 3.2.2-1, part A, and 3.2.2-4). If not flexible, it can be stopped at the outside edge of the nailer (Figure 3.2.2-1, part b). When a wood cant strip is present, the membrane can be stopped at the cant and fastened at the nailer. A strip of membrane or flashing, as appropriate, can be adhered to the cant and membrane to seal. Caulking the joints may be needed, as specified by the membrane manufacturer (see Figure 3.2.2-2).

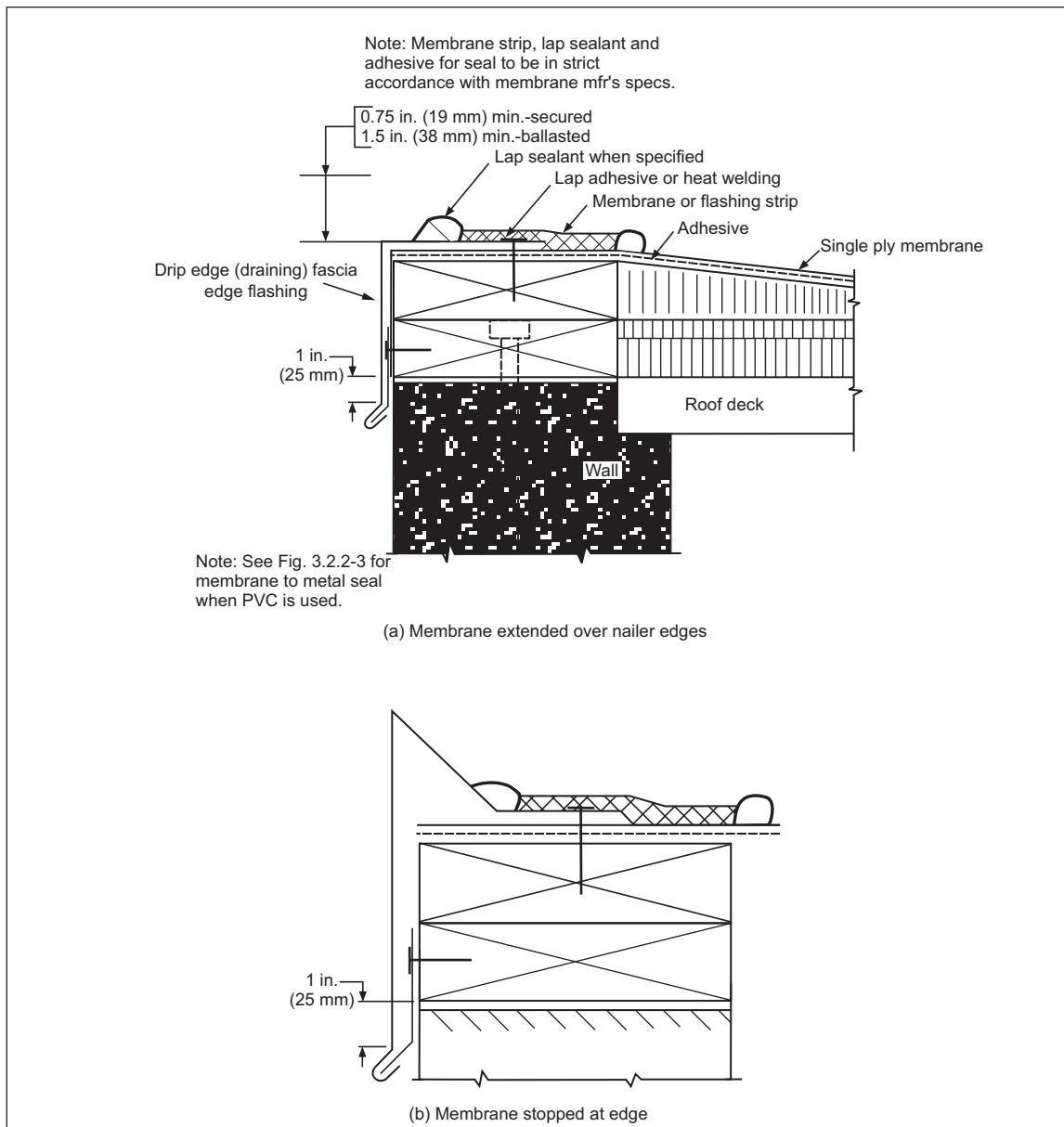

Fig. 3.2.2-1. Single-ply membrane with metal gravel guard fascia flashing

For certain membranes, it may be difficult to seal directly to the metal at the job site. The membrane manufacturer may be able to supply a factory-assembled laminate of the membrane material on the metal for use in such cases (see Figure 3.2.2-3).

3.2.3 Reglets

Reglets are notches that are built, cut, or formed on the inside face of a masonry parapet wall to receive the upper termination of the metal counterflashing. The metal protects the membrane termination from the weather (see Figure 3.2.3-1).

A reglet having an upward slope is preferred, as the metal also can be sloped. This will prevent water from seeping in behind the metal and finding its way under the membrane. The space between the metal and upper surface of the reglet should be caulked with a specified, good quality caulking compound.

When the wall is concrete, the reglet can be constructed by use of a sheet metal form. An exception may exist when the wall is precast and relatively thin. In this case, the wall could be significantly weakened by

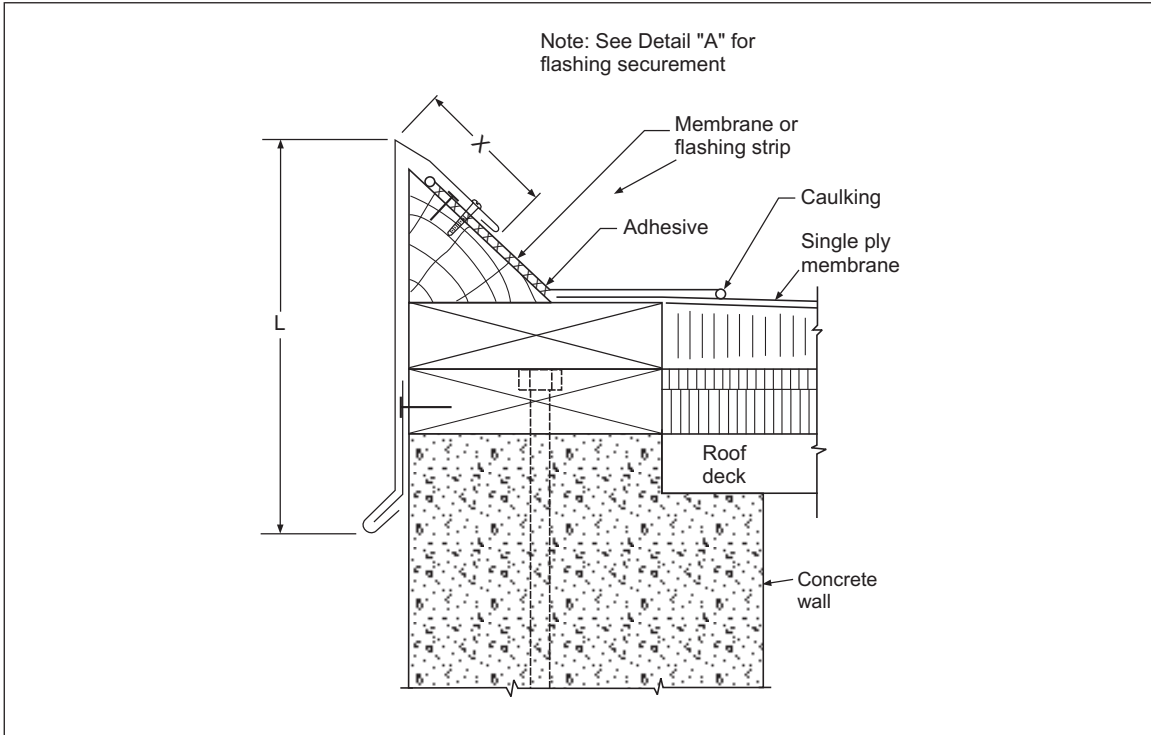

Fig. 3.2.2-2. Single-ply membrane roof with edge cap (cant) fascia flashing

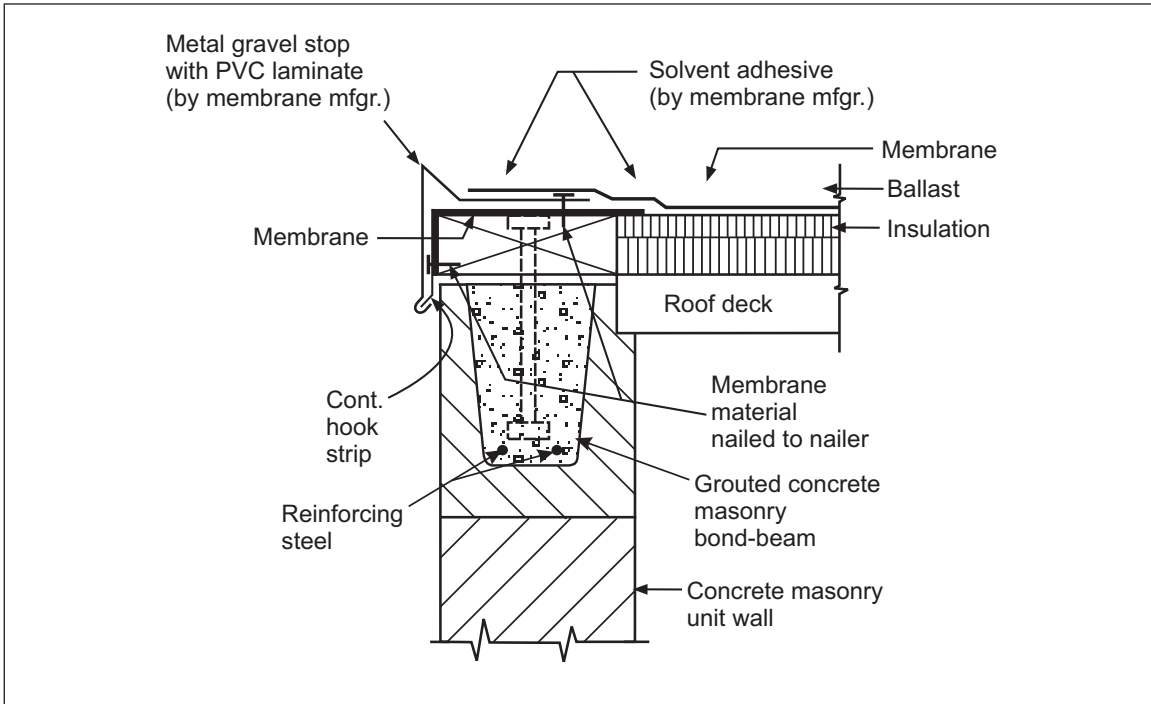

Fig. 3.2.2-3. PVC membrane edge detail with gravel stop

forming or cutting a reglet. When the wall is masonry, the reglet can be made at a joint by raking out the mortar. The sheet metal should be sloped outward and, in masonry walls, the metal should have a 135° bend that will help to hold it in place after it is inserted.

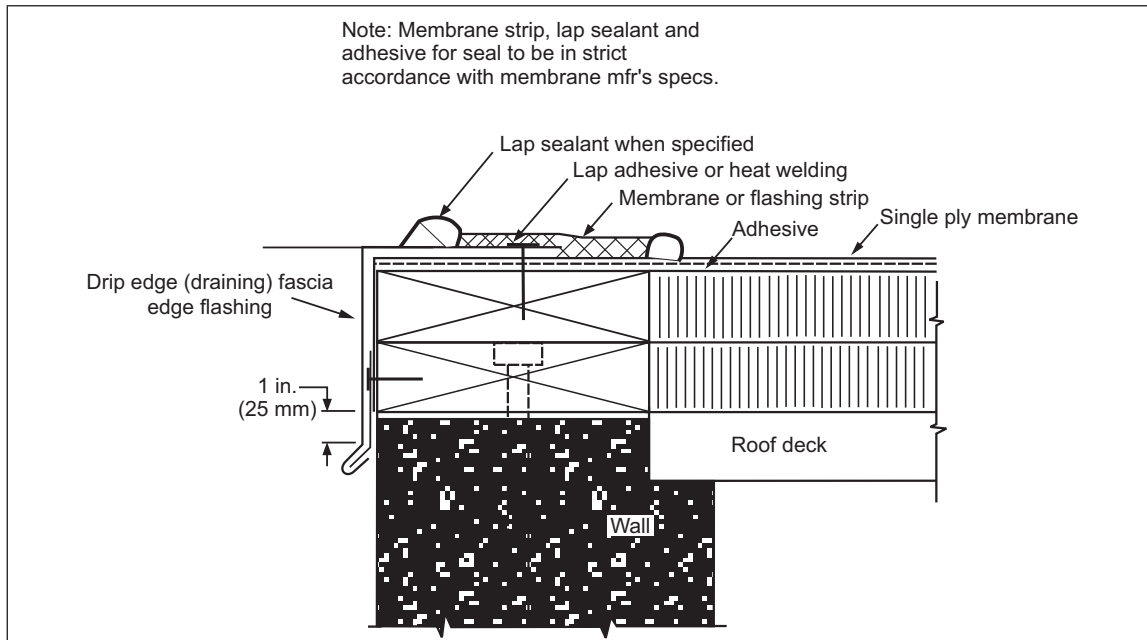

Fig. 3.2.2-4. Single-ply membrane roof with drip (drainage) fascia flashing

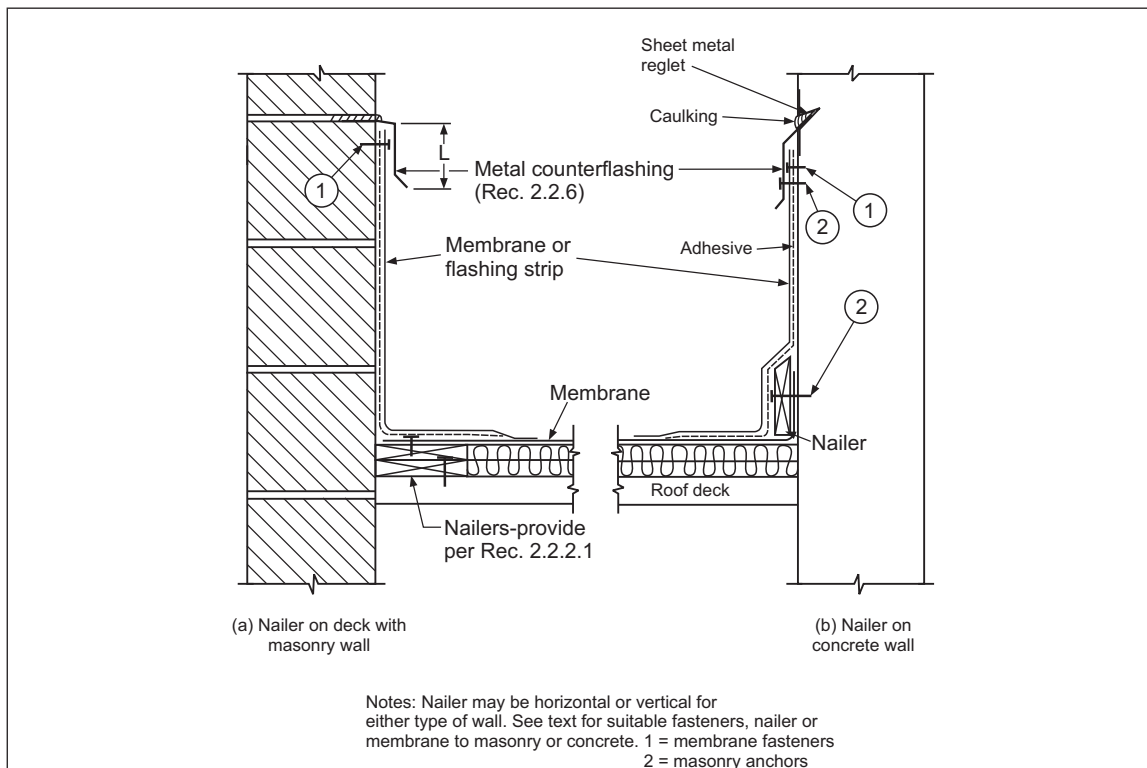

Fig. 3.2.3-1. Single-ply membrane wall or parapet terminations with reglets

When a concrete wall or parapet does not have a formed reglet, one can be cut using a concrete saw and chisel. This may be difficult, however, and there are other methods, such as: a) terminating the membrane at a point above the roof higher than the maximum expected rain or snow elevation and protecting it with a termination bar or metal counterflashing (Figure 3.2.3-2 Single-ply membrane attachment to precast walls (where reglet was not formed) or fastening the membrane to the face of the parapet under the coping cap and

adhering it to the wall by adhesives (Figure 3.2.3-3 Single-ply membrane termination under parapet coping). Caution should be used, however, because the distance a single-ply membrane or flashing can be run up a wall depends on variables such as membrane strength, adhesive type, wall roughness, etc. The safe distance before mechanical fastening is needed usually no more than four or five feet. See recommendation 2.2.5.

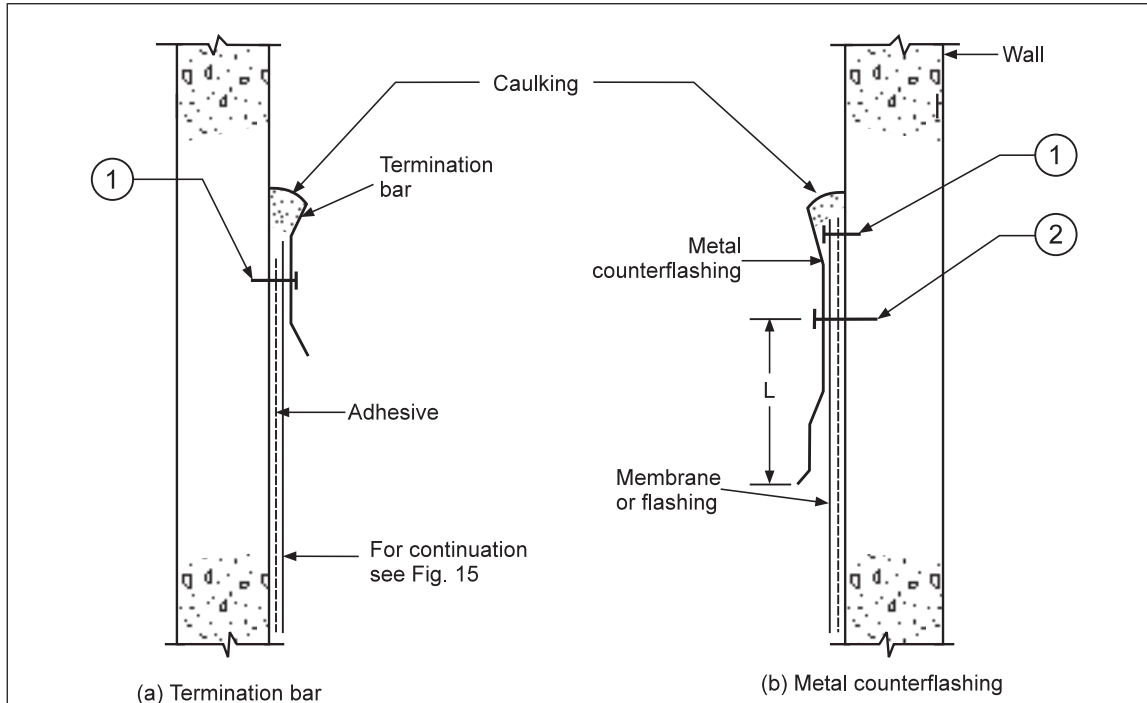

Fig. 3.2.3-2. Single-ply membrane attachment to precast walls (where reglet was not formed)

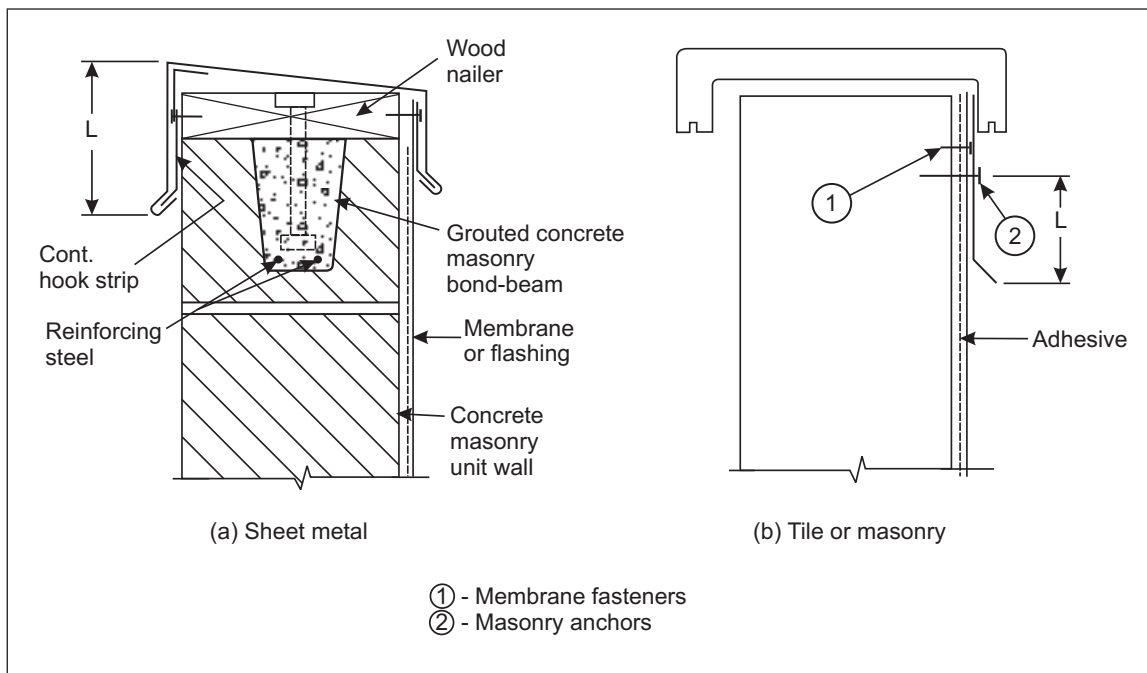

Fig. 3.2.3-3. Single-ply membrane termination under parapet coping

3.2.4 Termination Bars

When individual fasteners are used at the membrane termination, local stresses are introduced into the fabric around the fastener. This is due to the dead weight of the membrane, along with possible contraction forces in the membrane. Fasteners need to be spaced closely to prevent sagging. The termination bar is a continuous metal or plastic bar that is attached to the wall with fasteners that penetrate the membrane. The bar tends to distribute forces in the membrane more evenly so fasteners need not be spaced as closely. Termination bars are of many shapes, such as angular, channel-shaped or curved. Good stiffness is needed to distribute the forces at the fasteners. As the membrane termination needs caulking to prevent entry of water behind it, the bar sometimes has the top turned outward to hold the caulking. Also, the bottom of the bar can be bent outward to direct dripping water away from the wall (see Figure 3.2.3-2, part a).

Termination bars are not preferred over metal flashing inserted into reglets. They may be used in special cases where cutting a reglet may weaken the wall, or where it is difficult to cut a reglet into an existing wall. A good quality specified caulking compound is necessary to seal the space between the termination bar and the wall.

Metal counterflashing may also be used to protect the membrane termination (see Figure 3.2.3-2, part b)..

3.2.5 Masonry Anchors and Fasteners

For attachment of metal counter flashing or wood nailers to a masonry wall, drill holes and insert masonry anchors (Fastener No. 2; see Figure 3.2.3-1, part b, and Figure 3.2.3-2, part b). Resistance is provided by expansion sleeves or threads on the anchor. Spacing is usually about 12 in. (300 mm). Plastic parts should not be used in these anchors. The penetrating type of fastener driven into the masonry by impact is not considered reliable. Membrane manufacturers can supply appropriate fasteners for securement of the membrane at its upper termination (Fastener No. 1; see Figures 3.2.3-1, part b, and Figure 3.2.3-2, part b). Spacing of these fasteners depends on a number of factors, such as fastener strength, membrane strength, whether a termination bar is used, height of membrane up a parapet wall, elasticity, dead weight, contractual forces, etc. Fasteners are often spaced in the range of 4 to 6 in. (100 to 150 mm) when no termination bar is used; however, spacing and type of fastener should be in accordance with the membrane manufacturer's specifications. When a sheet metal flashing covers the termination, the same fastener may be used to secure both membrane and metal. However, spacing and type of fastener should be in accordance with the membrane manufacturer's specifications. When a sheet metal flashing covers the termination, the same fastener may be used to secure both membrane and metal.

3.2.6 Parapets

Sometimes owners wish to carry the membrane up the face of the parapet and under the coping cap. This may be done when the parapet is low, or if the owners wish to cover deteriorating masonry. As it may be difficult to fasten the membrane under some masonry copings (Figure 3.2.3-3, part b), it may be simpler to remove the coping and carry the membrane partly under it. The coping can be either reset or replaced with sheet metal (Figure 3.2.3-3, part a).

3.2.7 Base Securement of Adhered Single-Ply Membranes with Reinforced Membrane Attachment Strips (RMAS)

Figures 3.2.7-1 and 3.2.7-2 show typical details for RMAS used as base securement for fully adhered single-ply membranes. The un-adhered section of the RMAS will vertically deflect (bubble up) during wind uplift making the single-ply membrane susceptible to peeling. Vertical deflection (bubble) during laboratory wind uplift testing on a flat roof sample (no parapet wall) is shown in Figure 3.2.7-3. Vertical deflection is reduced by following recommendations in Section 2.2.4.

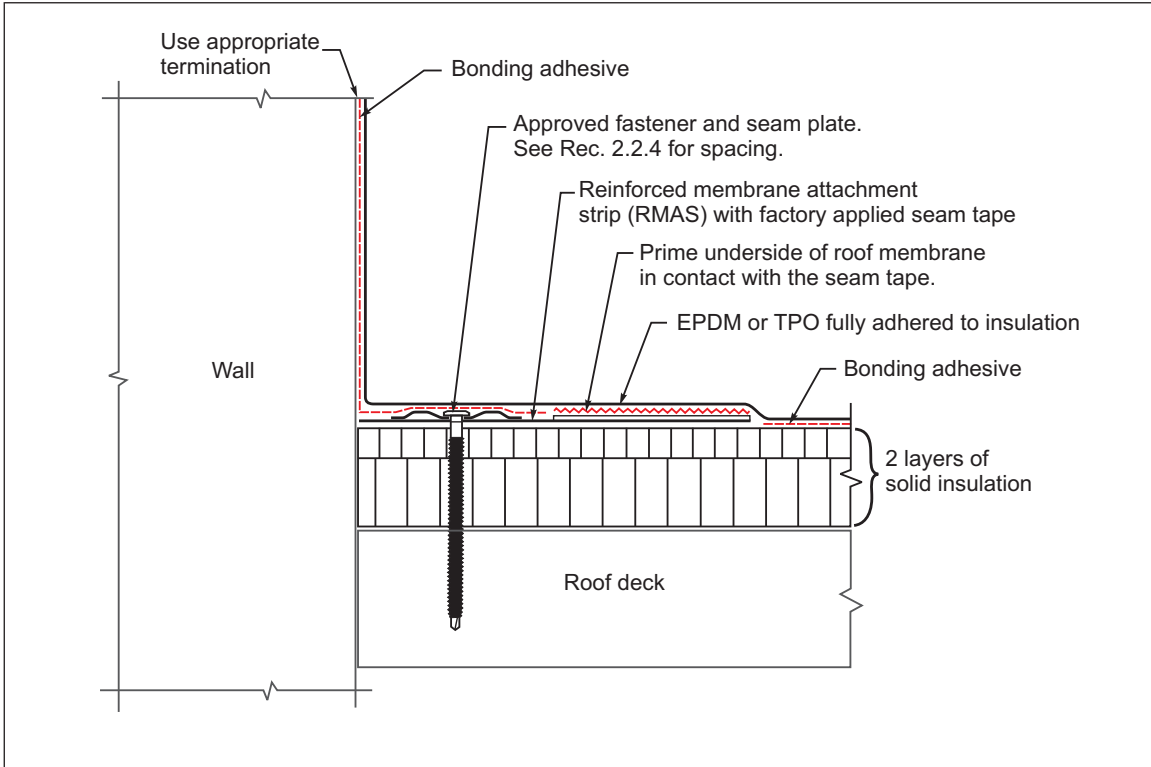

Fig. 3.2.7-1. Reinforced membrane attachment strip secured to roof deck

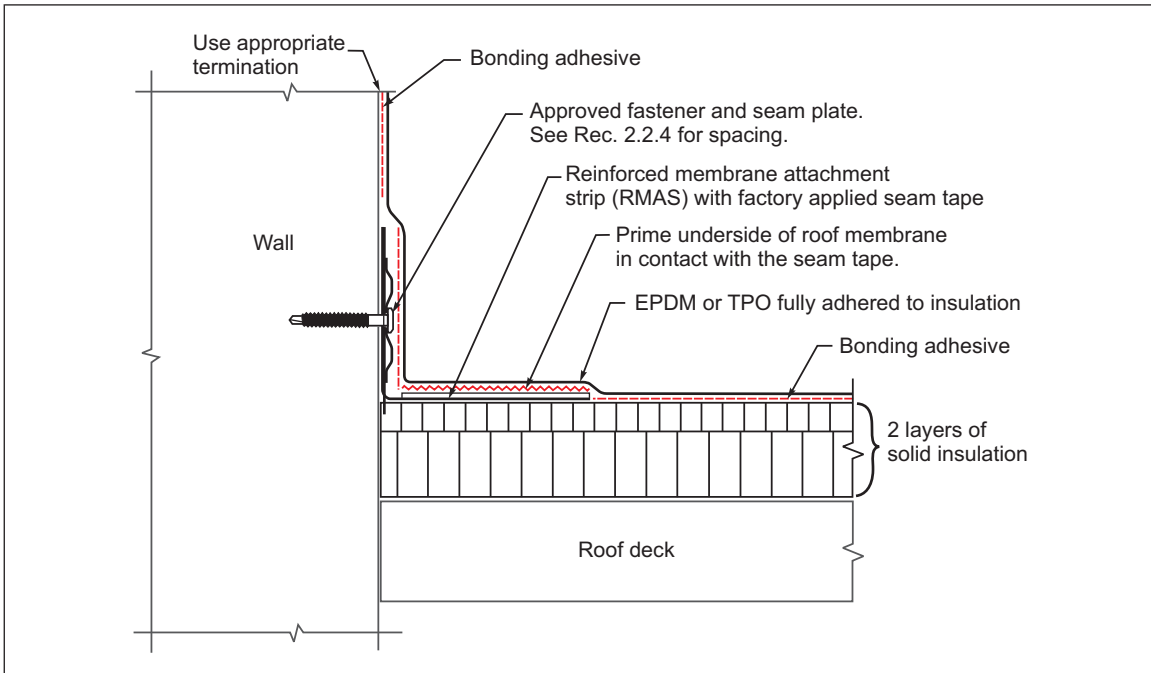

Fig. 3.2.7-2. Reinforced membrane attachment strip secured to a wall

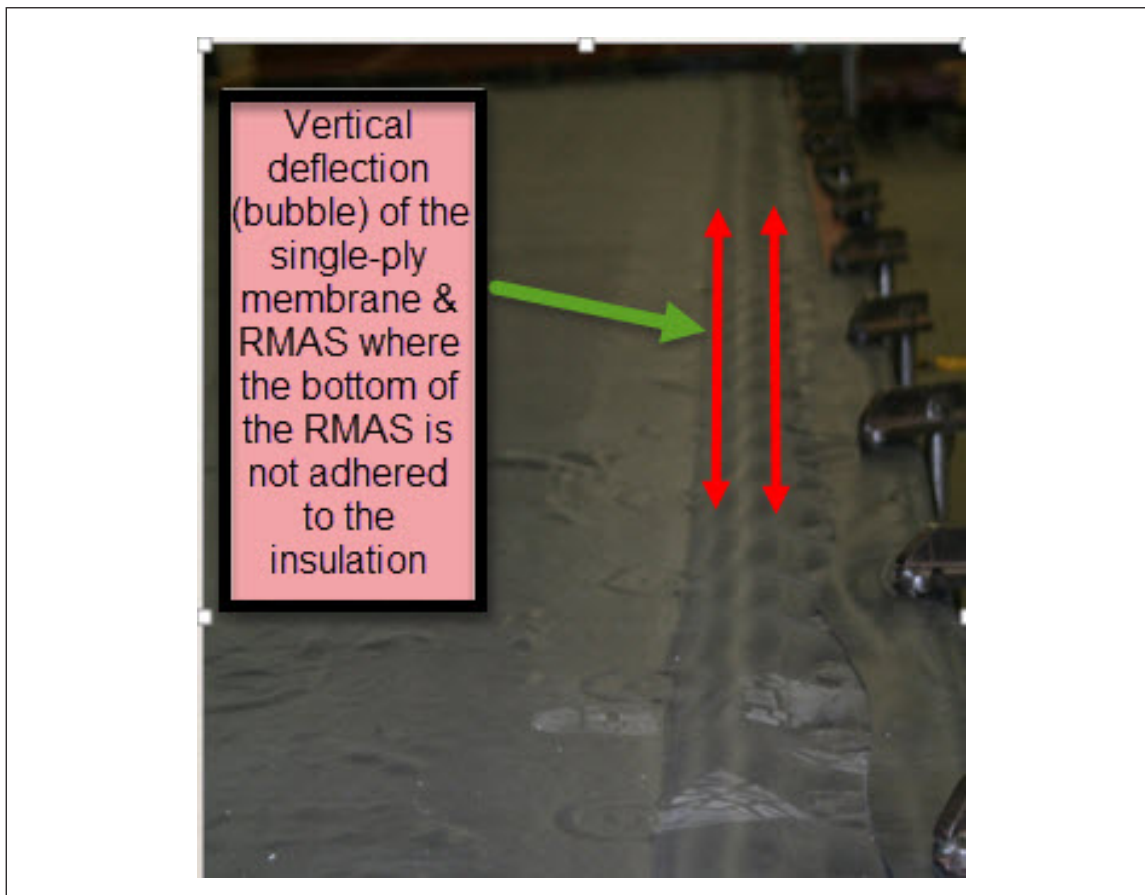

Fig. 3.2.7-3. Wind uplift test on adhered single-ply membrane with reinforced membrane attachment strip (RMAS)

3.3 Roof Penetrations

Openings are necessary in the structural roof and covering wherever pipes, vents, structural members, curbs, etc. pass through. The National Roofing Contractors Association publishes standard flashing details that are generally appropriate. Roof penetrations have not been an appreciable factor in roof wind losses but should be evaluated for their long-range water-tightness.

3.4 Resistance of FM Approved Flashing

The minimum upward and horizontal outward resistances of FM Approved coping and gutter systems are listed in Table 3.4-1. Fascias meet the minimum horizontal outward resistances in this table. These resistances may be used to verify compliance with building codes.

FM Approved flashing meets *Approval Standard for Edge Systems Used with Low Slope Roofing Systems*, Class Number 4435 (June 2013). RE-1, RE-2, and RE-3 tests in that standard are from the *Wind Design Standard for Edge Systems Used with Low Slope Roofing Systems*, SPRI/FM 4435/ES-1, 2011.

Table 3.4-1. Minimum Resistances for FM Approved Flashing Systems¹

RoofNav Flashing Rating	Zone 2 / Perimeter Flashing Resistance		RoofNav Flashing Rating	Zone 3 / Corner Flashing Resistance	
	Uplift Resistance psf (kPa)	Horizontal- Outward Resistance psf (kPa) ¹		Uplift Resistance psf (kPa)	Horizontal- Outward Resistance psf (kPa) ¹
1-60 Zone 2 Perimeter	101 (4.8)	58 (2.8)	1-60 Zone 3 Corner	152 (7.3)	73 (3.5)
1-75 Zone 2 Perimeter	126 (6.0)	73 (3.5)	1-75 Zone 3 Corner	190 (9.1)	91 (4.3)
1-90 Zone 2 Perimeter	151 (7.2)	87 (4.2)	1-90 Zone 3 Corner	228 (10.9)	109 (5.2)
1-105 Zone 2 Perimeter	176 (8.4)	102 (4.9)	1-105 3 Corner	266 (12.7)	127 (6.1)
1-120 Zone 2 Perimeter	202 (9.7)	116 (5.6)	1-120 3 Corner	304 (14.5)	145 (7.0)
1-135 Zone 2 Perimeter	227 (10.9)	131 (6.3)	1-135 3 Corner	342 (16.4)	163 (7.8)
1-150 Zone 2 Perimeter	252 (12.1)	146 (7.0)	1-150 3 Corner	380 (18.2)	182 (8.7)
1-165 Zone 2 Perimeter	277 (13.3)	160 (7.7)	1-165 3 Corner	417 (20.0)	200 (9.6)
1-180 Zone 2 Perimeter	302 (14.5)	175 (8.4)	1-180 3 Corner	455 (21.8)	218 (10.4)
1-195 Zone 2 Perimeter	328 (15.7)	189 (9.1)	1-195 3 Corner	493 (23.6)	236 (11.3)
1-210 Zone 2 Perimeter	353 (16.9)	204 (9.8)	1-210 3 Corner	531 (25.0)	253 (12.2)
1-225 Zone 2 Perimeter	378 (18.1)	218 (10.5)	1-225 3 Corner	569 (27.3)	271 (13.0)
1-240 Zone 2 Perimeter	403 (19.4)	233 (11.2)	1-240 3 Corner	607 (29.1)	289 (13.9)
1-255 Zone 2 Perimeter	428 (20.3)	247 (11.9)	1-255 3 Corner	645 (31.0)	307 (14.8)
1-XRatings available in increments of 15 psf (0.718 kPa)	3.36 * X/2	1.94 8 X/2	1-XRatings available in increments of 15 psf (0.718 kPa)	5.06 * X/2	2.41 * X/2

Note 1. Fascias only meet horizontal outward resistances.

3.5 Example Problems

3.5.1 Example Problem 1: Fully Adhered Roof Cover

Determine the recommended zone 2 perimeter and zone 3 corner ratings for FM Approved coping and fascia flashing, dimensions of the zone 3 corner area, fastening requirements for the wood nailer, and search for the recommended coping. There is a fully adhered roof cover on the following building:

Building dimensions are 200 x 300 ft (61 x 91 m) with a roof eave height (h) of 25 ft (7.5 m) and a 6° roof slope. It's in an area with a basic wind speed (V) of 100 mph (45 m/s), in a tropical cyclone prone region near sea level, surface roughness exposure C, and a topographic factor (Kzt) of 1.0. The building is enclosed with a fully adhered single-ply membrane roof cover and the walls are reinforced concrete masonry units.

3.5.1.1 Solution to Example Problem 1

3.5.1.1.1 The following results are obtained from RoofNav's Ratings Calculator output (see Figure 3.5.1.1.1-1).

A. 1-75 zone 2 perimeter rated coping or 1-60 zone 2 perimeter rated fascia is recommended in zone 2.

1-75 zone 3 corner rated coping or 1-60 zone 3 corner rated fascia is recommended in zone 3.

B. 1-90 rated roof is recommended in zone 1 (Recommendation 2.2.1.2).

C. The length of zone 3 is 15 ft (4.5 m) on each side of the corner. (Length of zone 3 is 0.6 x the 25 ft [7.5 m] roof height).

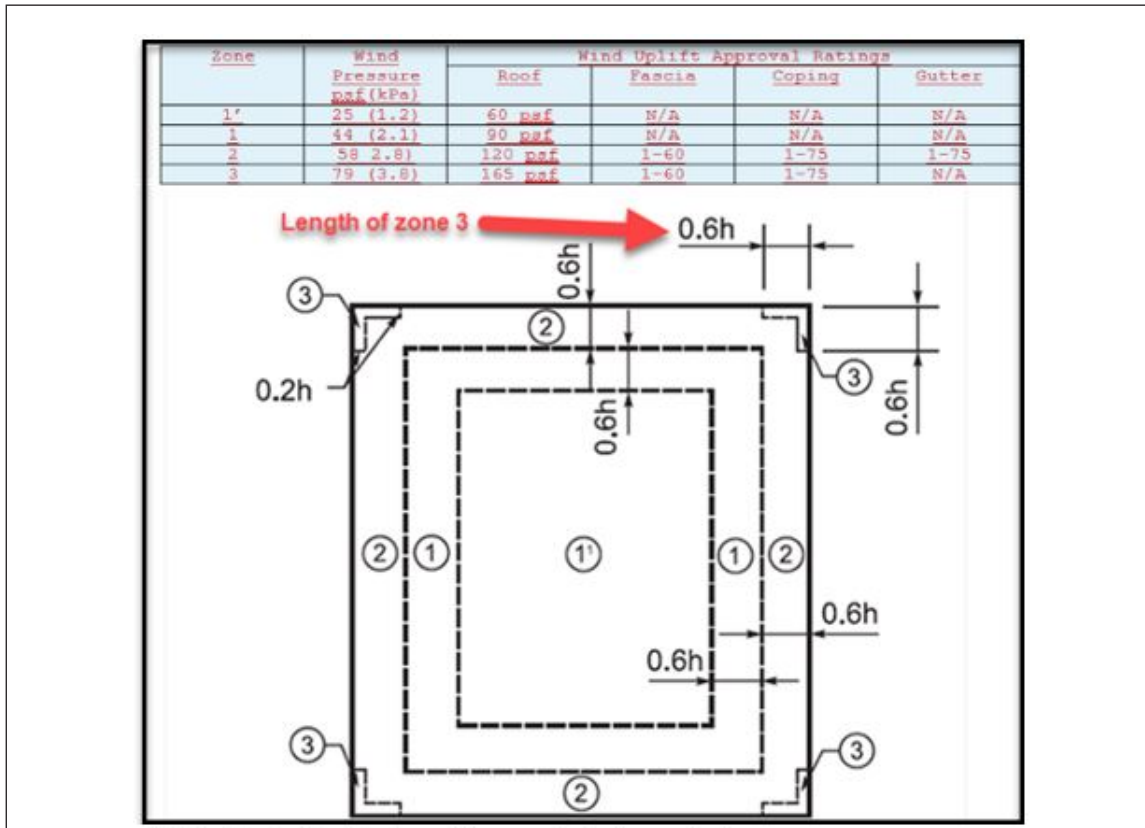

Fig. 3.5.1.1.1-1. RoofNav's ratings calculator output

3.5.1.1.2 Search for the recommended coping by inputting the recommended 1-75 zone 2 perimeter rating for coping into RoofNav's Product Search for coping as shown in Figure 3.5.1.1.2-1.

3.5.1.1.3 Select the make of coping from the search results, open "Please click for more details" in the Product Detail Report as shown in Figure 3.5.1.1.3-1.

Figure 3.5.1.1.3-2 shows all the Approvals and ratings for that make of flashing. These may be different for other makes of flashing.

Any of the FM Approved flashing on rows 3 – 5 are recommended since they each have Zone 2 perimeter ratings of 1-75 or higher and Zone 3 Corner ratings of 1-75 or higher.

The first two selections are not adequate because they do not have a minimum 1-75 Zone 3 Corner rating.

Conduct a new search with a higher wind rating if flashing with adequate ratings is not found.

The height of the vertical face should be wide enough for the drip edge bend to be a minimum 1 in. (25 mm) below the bottom of the bottom nailer.

3.5.1.1.4 Following Recommendation 2.2.1.4, determine if the roof cover is independently terminated or dependently terminated.

This is an independently terminated roof cover because it is fully adhered. No additional edge securement is needed.

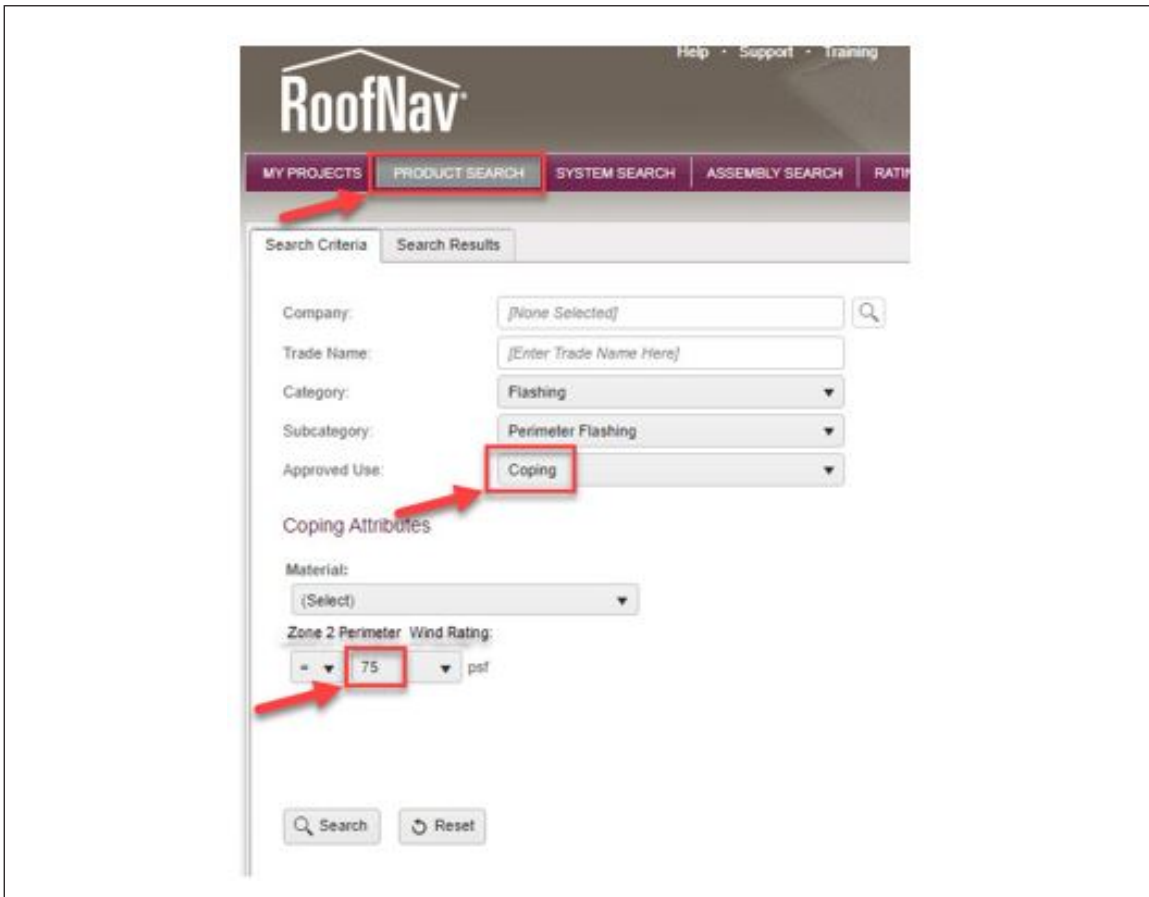

Fig. 3.5.1.1.2-1. RoofNav's product search

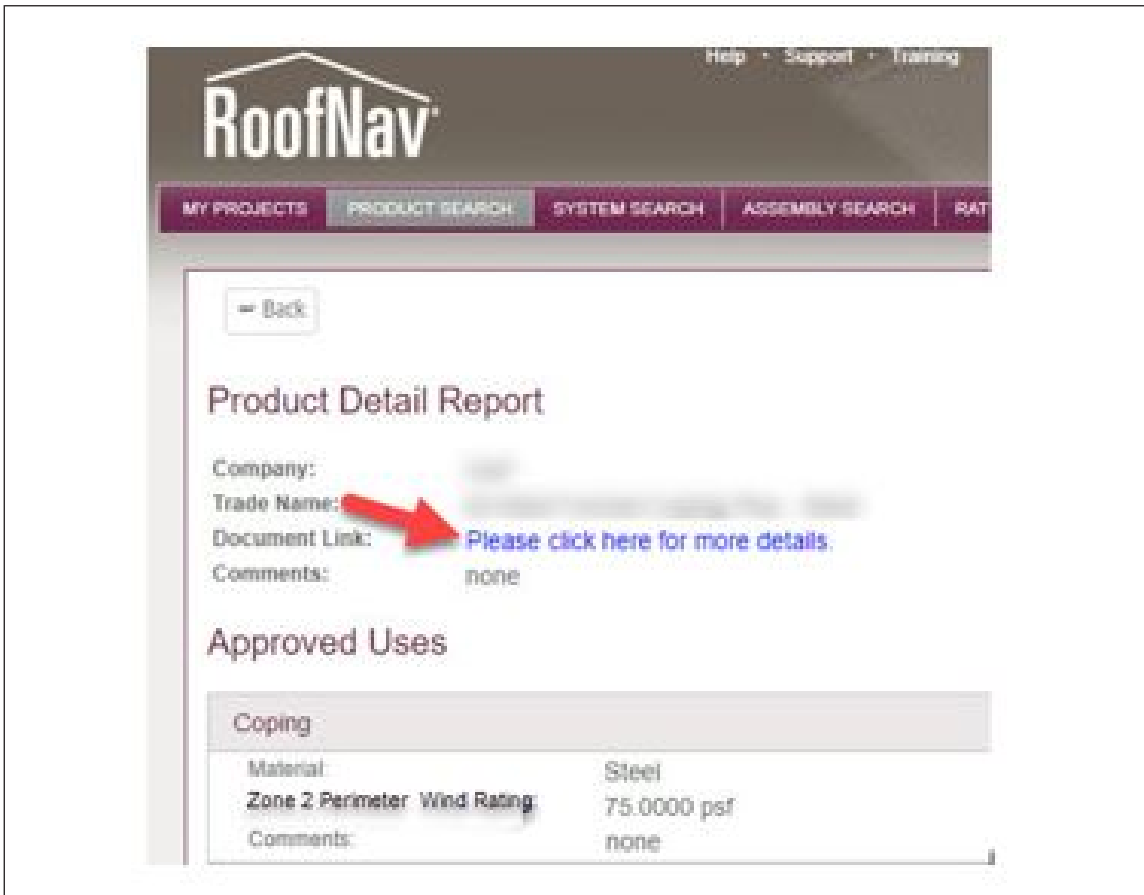

Fig. 3.5.1.1.3-1. RoofNav's product detail report

Material	Max Face Height in. (mm)	Max Wall Width in. (mm)	Max Back Height in. (mm)	Zone 2 Perimeter Rating	Zone 3 Corner Rating
Not Recommended	10 (254)	32 (813)	6 (152)	1-75	-
	3 (76)		1 (25)	1-90	1-60
	6 (152)	24 (610)	4 (102)	1-120	1-75
Recommended	6 (152)	16 (406)	4 (102)	1-120	1-75
	6 (152)	16 (406)	4 (102)	1-270	1-180

Fig. 3.5.1.1.3-2. RoofNav's product details

3.5.1.1.5 Using Table 2.2.2.3.2-1 in which a 1-90 roof is recommended in Zone 1, space ½ in. (13 mm) anchor bolts for the wood nailer a maximum of 48 in. (1200 mm) in Zone 2 and 24 in. (600 mm) in Zone 3. Embed anchor bolts a minimum of 5 in. (125 mm) into the concrete bond beam (Recommendation 2.2.2.3.2).

3.5.1.1.6 Use minimum 1-1/2 by 5-1/2 in. (38 by 140 mm) wood nailers with maximum ¼ in. (19 mm) countersink for the bolts and washers (Recommendation 2.2.2.2).

3.5.1.1.7 If a wood cant strip is used, secure it to the wood nailer using the fastening spacing in Table 2.2.2.3.6-1 where a 1-90 roof is recommended in Zone 1. This is two staggered rows of minimum 10 penny (3 in.; 75 mm) nails or no. 8 (4 mm dia.) screws spaced a maximum of 24 in. (600 mm) in each row in Zone 2 and 12 in. (300 mm) in each row in Zone 3 which is 15 ft (4.5 m) on each side of the corner (Recommendation 2.2.2.3.6).

3.5.1.1.8 Install FM Approved flashing using the type of fasteners and spacing shown in RoofNav (Recommendation 2.2.1.6).

3.5.2 Example Problem 2: Mechanically Fastened Roof Cover

Building features are the same as in Example Problem 1 except the roof has a mechanically fastened single-ply membrane with the first row of fasteners 4 ft (1.2 m) from the outside edge of the nailer in Zone 2, and 2 ft (0.61 m) from the outside edge of the nailer in Zone 3.

3.5.2.1 Solution to Example Problem 2

Same solutions as Example Problem 1, except for part 3.5.1.1.4. Because distances from the outside edge of the nailer to the first row of fasteners in Zones 2 and 3 exceed 1 ft (300 mm), this is a dependently terminated roof cover. Following Recommendation 2.2.1.5, provide additional edge securement consisting of one row of FM Approved batten bars, stress plates, or reinforced membrane attachment strips (RMAS) within 12 in. (300 mm) of the outside edge of the nailer. Use fasteners FM Approved for the roof cover and deck spaced 6 in. (150 mm) maximum in Zones 2 and 3.

3.6 Loss History

The majority of roof covering failures resulting from windstorms involve improperly designed or constructed perimeter flashings. However, poorly secured insulation or roof covering is subject to damage even when perimeter flashing is properly designed and constructed. Because most windstorms are accompanied by rain, contents are immediately vulnerable to damage due to leakage resulting from perimeter flashing and/or roof covering securement failure.

Some flashing details involved in wind losses are shown in Figure 3.6-1. These details should not be used in the construction of flashings because adequate anchorage is not provided. In Example 1, failure occurred when steel anchors pulled out of the masonry. In Example 2, failure occurred either because the metal flashing was too thin or because there was no hook strip. Wind forces bent the flashing upward, with the resulting prying action causing the nail fastening to pull out. Failure of the bolts that anchor the nailer to the deck can result in the same situation. In Example 3, the wood blocking to which the cant strip is attached was fastened to the brick with short nails driven vertically into the masonry joints. The entire detail failed when these nails pulled out. In Example 4, failure occurred because the wood blocking was not anchored to the masonry or steel and the entire assembly was displaced.

A number of failures have occurred when attempts were made to secure the nailer, either by driving nails through it and into the edges of the hollow masonry, or into wood blocks wedged into the masonry cores. Securing the nailer in this manner is not adequate.

Bolts anchored into the masonry joints may not hold under severe wind conditions. See Recommendation No. 2.2.2.3.2 for proper anchorage methods.

3.7 Illustrative Losses

3.7.1 Hurricane Winds Strike Building Corner

A large warehouse was occupied for the storage of automatic transmissions. The roof was constructed of 22 gauge, intermediate rib steel deck welded to steel joists. The insulation was glass fiber topped with built-up covering. The wood nailer along the perimeter was attached to a steel beam below with 1/8 in. (3.2 mm) penetrating nails applied with a gun and spaced every 2 to 2.5 ft (0.6 to 0.8 m).

A hurricane passed through the area with winds gusting to 80 mph (36 m/s). A section of flashing and nailer in the southeast corner of the building was lifted off and 5000 ft² (465 m²) of insulation and covering was removed. Heavy rain along with broken sprinkler piping severely wetted the stored automatic transmission parts (steel, aluminum, rubber, and brass); however, most of the contents were salvaged.

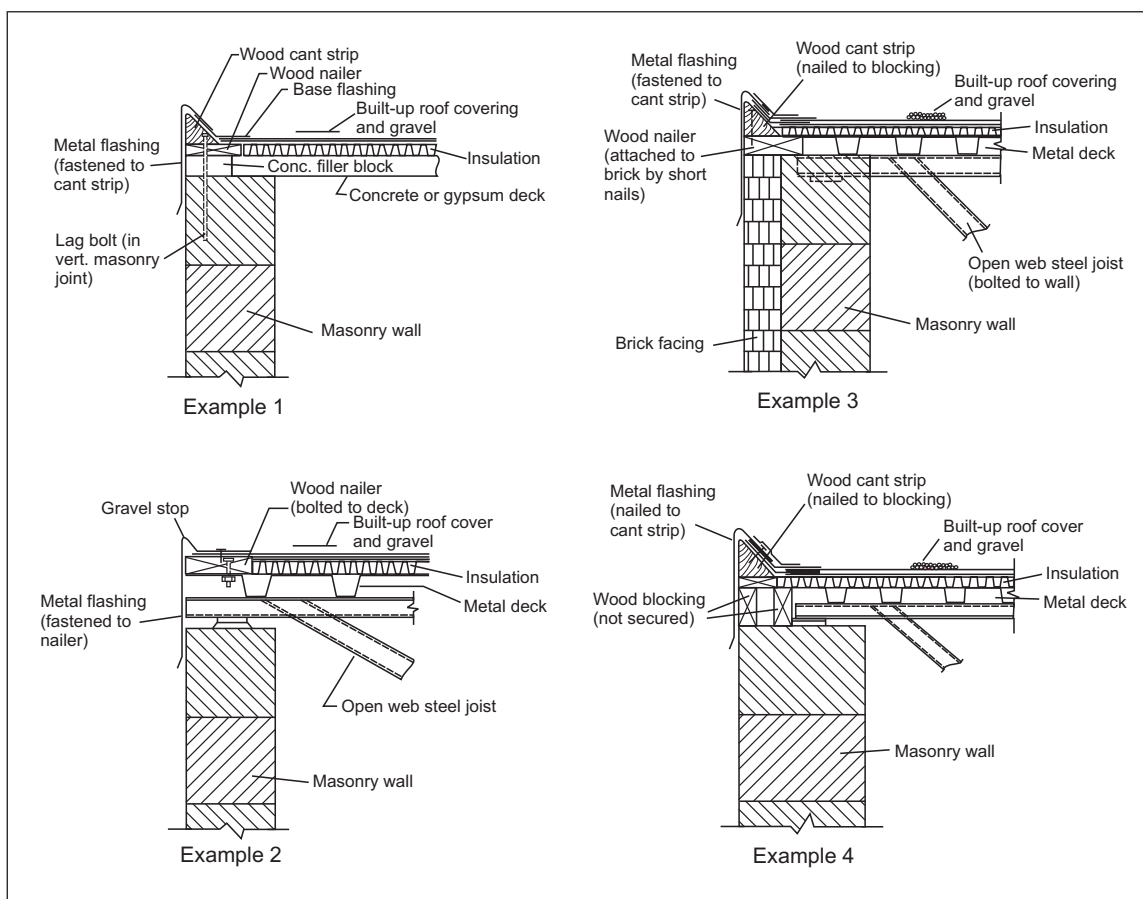

Fig. 3.6-1. Examples of perimeter flashing installations THAT ARE NOT RECOMMENDED

Upon examination of the damaged section, it was noted that the steel penetrating nails securing the nailer had broken off. The nail size and spacing near the building corners were considerably less than the FM Global recommended 1/2 in. (13 mm) steel bolts spaced 2 ft (610 mm) apart (or 3/8 in. [10 mm] bolts spaced 24 in. [600 mm] apart) in Zone 3 for 1-90 systems.

3.7.2 Hook Strip Not Provided

A wood nailer was anchored to the top of a concrete block wall. The horizontal part of metal perimeter flashing was attached to the nailer with fasteners 2 ft (0.6 m) apart. The vertical (fascia) that extended down over the outside face of the wall was secured by screws 5 ft (1.5 m) apart into the nailer. Winds of 55 mph (25 m/s) ripped the metal flashing off. The roof covering and insulation suffered damage only in the vicinity of the torn-off flashing. There was a recommendation to provide a continuous hook strip secured 12 in. (305 mm) on center in Zone 2 and 8 in. (203 mm) on center in Zone 3.

3.7.3 Hooking of Metal Fascia Inadequate

A building was designed with structural steel beams exposed below the eave. The walls were masonry built up to the underside of the beams. A metal flashing fascia extended down over the edge of the covering, insulation, and deck. A hook had been made in the lower part of the fascia metal in an attempt to secure it around the upper beam flange. Winds estimated at 39 mph (17 m/s) tore off a section of the flashing and loosened insulation in the adjacent 4 X 30 ft (1.2 X 9.0 m) area. The hook pulled away as there was no thin, vertical element on the beam. A recommendation was made for sections of steel angle, installed with one leg downward, to be welded to the flange.

In other cases, perimeter flashing was blown off due to inadequate anchorage of the wood nailer to steel deck. These losses were caused by use of common nails (smooth shank), or a single row of screws placed 2 ft (0.61 m) or more apart driven through the nailer and deck.

4.0 REFERENCES

4.1 FM Global

Data Sheet 1-28, *Wind Design*

Data Sheet 1-29, *Roof Deck Securement and Above-Deck Roof Components*

Data Sheet 1-32, *Inspection and Maintenance of Roof Assemblies*

Data Sheet 1-42, *MFL Limiting Factors*

Data Sheet 1-54, *Roof Loads and Drainage*

FM 4435, *Approval Standard for Edge Systems Used with Low Slope Roofing Systems*, June 2013

RoofNav, FM Approvals

4.2 Others

American Concrete Institute. *Building Code Requirements for Structural Concrete (ACI 318-19) and Commentary*. 2019 Edition.

American Wood Council. *ANSI/AWC NDS-2018 ASD/LFRD NDS National Design Specification for Wood Construction*. 2018 Edition.

ASTM International. *Standard Specification for Grout for Masonry*. ASTM C476-2020.

ASTM International. *Standard Specification for Perlite Thermal Insulation Board*. C728-17a.

ASTM International. *Standard Specification for Zinc Coating (Hot-Dip) on Iron and Steel Hardware*. ASTM A153/A153M-16a.

Masonry Standards Joint Committee. *Building Code Requirements and Specifications for Masonry Structures*. 2016 Edition.

National Roofing Contractors Association (NRCA). *The NRCA Roofing Manual: Membrane Roof Systems*, 2019 Edition.

National Roofing Contractors Association (NRCA). *The NRCA Roofing Manual: Architectural Metal Flashing, Condensation and Air Leakage Control*, 2018 Edition.

Single Ply Roofing Industry (SPRI) ANSI/SPRI/FM 4435/ES-1 *Wind Design Standard for Edge Systems Used with Low Slope Roofing Systems*. 2011.

APPENDIX A GLOSSARY OF TERMS

Additional edge securement: A termination device, typically batten bars, stress plates or reinforced membrane attachment strips, installed approximately 12 in. (300 mm) away from the roof edge, parapet wall or angle change. It is fastened to the roof deck with fasteners spaced 6 in. (150 mm) maximum in the Zones 2 and 3. When installed within 12 in. (300 mm) of the outside edge of the nailer it changes a dependently terminated roof cover to an independently terminated roof cover. This is sometimes referred to as a “peel stop” because it reduces “peeling” of adhered roof covers.

Bonded sealing washer for roofing fasteners: A metal washer that has an elastomeric material, commonly ethylene propylene diene terpolymer (EPDM) or neoprene, that is bonded to it. Materials should be selected based on the environmental conditions and other materials, such as oils or grease, that may be present.

Cap flashing: A flashing used to cover the top of various building components.

Cant strip: A beveled strip used to change the angle where the roofing membrane meets a vertical component.

Cleat: A continuous metal strip or angled piece used to secure metal components.

Clip: A non-continuous metal component or angle piece used to secure two or more metal components together.

Coping: The covering piece on top of a parapet wall that is exposed to the weather and normally sloped to carry off water.

Coping width: The smallest horizontal dimension of the coping section.

Corner Length: The distance in each direction from an outside corner where wind pressures are higher and usually require stronger flashing assemblies. See D.S. 1-28 to determine the distance.

Dependently terminated (DT) roof systems: Constructions where the edge of the membrane is structurally dependent on the flashing for securement. This includes ballasted systems, ribbon adhered systems, or mechanically attached roof covers terminating at a roof edge (not terminating at higher vertical walls or parapets) where the distance from the outside edge of the nailer to the first row of fasteners or adhesive ribbons parallel to the edge of the building is greater than 12 in. (305 mm.)

Drip Edge: The lower part of flashing or other component with an outward projecting lower edge, intended to control the direction of dripping water and help protect underlying building components. See Fig. 3.2.2-2 Single-ply membrane roof with edge cap (cant) fascia flashing.

FM Approved: Products and services that have satisfied the criteria for Approval by FM Approvals. Refer to RoofNav and the Approval Guide, online products of FM Approvals, for a complete listing of products and services that are FM Approved. FM Approval of roof perimeter flashing is limited to the fascia and coping types. Guidelines for securement of wood nailers contained in this document should also be followed because that is outside the scope of the Approval.

Fascia: The vertical or steeply sloped roof trim located at the perimeter of a building.

Fastener: Any of a wide variety of mechanical securement devices and assemblies, including nails, staples, screws, cleats, clips and bolts, which may be used to secure various components of a roof. .

Gravel stop: A flanged device designed to prevent loose aggregate from washing off the roof and to provide a continuous finished edge for the roofing. Can be used with single-ply membranes without gravel or ballast.

Independently terminated (IT) roof systems: A construction where the edge of the membrane is structurally terminated independent of the flashing. This includes fully adhered systems, ribbon adhered, and mechanically attached roof cover systems where the distance from the outside edge of the nailer to the first row of fasteners or adhesive parallel to the edge of the building is less than or equal to 12 in. (305 mm).

Metal counterflashing: In this document, a formed metal component attached to a wall and positioned over base flashing to protect it from the weather.

Nailer: A piece or several pieces of dimensional lumber or FM Approved metal nailers, secured to the structural deck or walls, which provides a receiving medium for the fasteners used to attach membranes, flashing or additional wood members.

Parapet Wall: The part of a perimeter wall that extends above the roof.

Perimeter flashing: Components used to weatherproof or seal roof system edges at the perimeters of buildings where the roof covering is interrupted or terminated.

Perimeter flashing system: An assemblage of components, including but not limited to, coping, fascia, clips, cleats, caps and fasteners, that when properly installed, will provide a wind uplift resistance in accordance with this standard.

Pressure-treated wood (PTW): Wood (typically southern yellow pine) which is pressure treated for rot and decay resistance. Current treatment materials include alkaline copper quaternaries (ACQ-C, ACQ-D with carbonate) and copper azoles (CBA-A and CA-B).

Reglet: A horizontal groove cut into a masonry wall to receive counter-flashing.

Reinforced membrane attachment strip (RMAS): Generic term for various manufacturer's narrow strip, 6 to 9 in. (150 - 225 mm) wide, of reinforced EPDM or TPO membrane which can be used to secure the membrane of same material to parapet walls. Includes seam sealing tape or seam sealing tape can be applied. It is usually screwed to the deck, wall using batten bars or stress plates.

Roof edge: The point of transition from a low-slope roof to a lower vertical or near vertical building element, including but not limited to walls, windows, fascia boards, and mansard roofs.

Roof edge system: A component or system of components at the perimeter of the roof that typically is integrated into the roof system for the purpose of flashing and securing the roof membrane

Zone 1: Roof area inside zones 2 and 3 and outside zone 1' (when present). See DS 1-28 for dimensions and diagrams.

Zone 2: The roof perimeter area between zone 3 (corners). See DS 1-28 for dimensions and diagrams.

Zone 3: The roof perimeter area at the corners. See DS 1-28 for dimensions and diagrams.

APPENDIX B DOCUMENT REVISION HISTORY

The purpose of this appendix is to capture the changes that were made to this document each time it was published. Please note that section numbers refer specifically to those in the version published on the date shown (i.e., the section numbers are not always the same from version to version).

October 2021. This document has been completely revised. The following significant changes were made:

- A. Revised design guidance for calculating flashing ratings to reflect changes in pressure coefficients in Data Sheet 1-28 and ASCE 7-16.
- B. Deleted Table 1 because RoofNav's Ratings Calculator is now used to calculate flashing ratings.
- C. Information in 2.2.7, Flashing Systems at MFL Fire Walls, has been deleted and recommends using Data Sheet 1-42, Maximum Foreseeable Loss Limiting Factors.

April 2020. Interim revision. Minor editorial changes were made.

February 2020. Interim revision. Editorial changes were made. Revisions reflecting changes to Data Sheet 1-28, *Wind Design*, were made. The primary changes were renaming the field, perimeter, and corner roof areas as Zone 1, Zone 2, and Zone 3, respectively.

July 2016. This document has been completely revised to include guidance for selecting perimeter roof flashing systems for roof systems greater than Class 1-90, and to reflect current construction practices such as when to provide wood nailers. Additional edge securement is recommended for dependently terminated roof systems.

Tests for FM Approved flashing have changed with FM 4435, *Approval Standard for Edge Systems Used with Low Slope Roofing Systems*, June 2013, using test methods in the *Wind Design Standard for Edge Systems Used with Low Slope Roofing Systems*, SPRI/FM 4435/ES-1, 2011.

September 2009. Minor editorial changes were made for this revision.

September 2000. This document was reorganized to provide a consistent format.

May 1998. The major change from the previous version was the addition of new text and details applicable to single-ply membranes. It was emphasized that the components of the flashing assembly exclusive of the membrane (anchor bolts, nailers, wood cants, flashing thickness, flashing attachment, and so forth) are essentially the same for both built-up and single-ply roofing membranes. The major change, therefore, was the addition of details that show membrane terminations for single-ply membrane roof coverings.

Perimeter flashing requirements are now evaluated as part of the approval of single-ply membranes. The approval standard specifies that the manufacturer use either an Approved flashing system or one that is designed in accordance with Data Sheet 1-49.

February 1985. Minor technical changes were made.

October, 1979. Numerous recommendations and figures were added to address specific guidelines related to the securement of flashing to wood nailers and cant strips. Information on gutter securement was also added.

February, 1977. The original version of what is now Table 2 was added. Discussion of the relationship between uplift pressures in the field, perimeter and corner roof areas was added, as well as the relationship between outward (horizontal) pressures and uplift pressures.

April 1970. The original version of this document was written. It included general discussion based on a study of losses from 1966 - 1967 as well as examples of both poor and good designs.